

# OPTIMUM DESIGN OF STEEL FRAMES COMPOSED OF TAPERED MEMBERS USING STRENGTH AND DISPLACEMENT CONSTRAINTS WITH GEOMETRICALLY NONLINEAR ELASTIC ANALYSIS

Haitham Ali Bady  
University of Qadisiya \College of Engineering

## Abstract

Design of steel tapered member under combined axial and flexural strength is somewhat complex if no approximations are made. However, recent Load Resistance Factor Design (LRFD) of the AISC code has treated the problem with sufficient accuracy and ease. The aim of this study is to present an algorithm for the optimum design of steel frames composed of tapered beams and columns with I-section in which the width is taken as constant, together with the thickness of web and flange, while the depth is considered to be varying linearly between joints. The objective function which is taken as the weight of the steel frame is expressed in terms of the depth at each joint. Both the displacement and combined axial and flexural strength constraints are considered in the formulation of the design problem. The strength constraints are expressed as a nonlinear function of the depth variables. The optimality criteria method is then used to obtain a recursive relationship for the depth variable under the displacement and strength constraints. Numerical examples are presented to demonstrate the practical application of the algorithm.

**Keywords:** Design, tapered, steel, axial, flexural, strength, constraints, optimum, nonlinear, stability

التصميم الأمثل للمنشآت الحديدية المركبة من أعضاء غير موشورية و باستخدام محددى الإزاحة و  
المقاومة تحت تأثير السلوك غير الخطي و المرن للمنشأ

هيثم علي بادي  
تدريسي في \ جامعة القادسية \ كلية هندسة

الخلاصة

LRFD

( )

( I )

( )

**Nomenclature**

$l_i$  is the length of the tapered member  $i$ .

$t_f, t_w$ , thickness of flange and web of the I-section of the tapered member respectively.

$b_f$  is the width of the flange

$\rho$  and  $V_i$  are the density and volume of typical tapered member

$i$  shown in **Fig.(1)** , respectively .

$nm$  is the total number of tapered members in the frame .

$D_i$  is the depth variable belonging to member  $i$ ,

$D_{1i}$  is the lower bound of the depth variable .

$g_{dj} (D_{1i}, D_{2i})$  represents  $j^{th}$  displacement constrains .

$g_{sri} (D_{1i}, D_{2i})$  represents strength constrains for member  $i$ .

$k$  Is the total number of restricted displacement.

$\delta_j$  is the displacement at node where constraints is wanted .

$\delta_{ju}$  is its upper bound.

$F_y$  is specified yield stress

$A_g$  is the gross area of the member at the smaller end.

$\lambda_{eff}$  is called the effective slenderness parameter.

$S_x$ , the sectional modulus of the larger end

$F_b$  is the design flexural stress of tapered member,

**Introduction**

Steel frames with tapered members were preferred in the design of structure whenever the architectural requirements allow their presence .They provide better distribution of strength as well as yield lighter design. The methods available for the analysis of such frames are well established (Haitham, 2000), (Oran, 1974) .In most of the practical design codes , approximate procedures are suggested for dimensioning tapered members which are subjected to the combined action of axial force and bending moment .

In this study, an optimum design algorithm is presented which takes into account the geometrical nonlinearity for steel frames with tapered members. This is achieved by coupling optimality criteria approach with large deformation analysis method of elastic tapered steel frame develops in Ref (2).

**Optimum Design Problem**

The optimum design problem a nonlinear steel frames composed of tapered members subjected to displacement and strength constraints can be expressed as follows :-

$$\text{Min } W = \sum_{i=1}^{nm} \rho_i V_i \quad i=1, \dots, nm \tag{1}$$

Subjected to

$$\begin{aligned} g_{dj} (D_{1i}, D_{2i}) &\leq 0 & j=1, \dots, k \\ g_{sri} (D_{1i}, D_{2i}) &\leq 1 & i=1, \dots, nm \\ D_{1i} - D_{1il} &\geq 0 & i=1 \dots nm \\ D_{2i} - D_{2il} &\geq 0 & i=1 \dots nm \end{aligned} \tag{2}$$

### **Objective Displacement**

The objective function, which is the total volume of frame, is obtained as a summation of weights of all members. The volume  $v_i$  of member  $i$  as shown in Fig. (1) can be expressed in terms of the values of the depth variables ( $D_{1i}$ ) and ( $D_{2i}$ ), as follow:-

$$V_i = \left[ \frac{(D_{1i} + D_{2i})}{2} t_w + 2t_f (b_f - t_w) \right] l_i \quad (3)$$

where  $D_{1i}$ ,  $D_{2i}$  is the depth variables of the smallest and largest end respectively of tapered member  $i$ .

of the I-section of the tapered member.

It can be seen that  $b_f$ ,  $t_f$  and  $t_w$  are selected to be constant throughout the frame, which leaves only the depths at nodes (1) and (2) as the design variables.

The elastic sectional modulus for symmetrical sections are calculated easily when the values of  $D_{1i}$  and  $D_{2i}$  are known.

### **Combined Axial and Flexural Strength Constraints**

The combined axial and flexural strength constraint for member  $i$ , which is subjected to axial force and bending moment about its major axis, is given in LRFD<sup>(4)</sup> as, for

$$P_u / (\phi P_n) \geq 0.2 \quad (4)$$

$$\frac{P_u}{\phi P_n} + \frac{8}{9} \frac{M_{ux}}{\phi_b M_{nx}} \leq 1 \quad (5)$$

and for

$$P_u / (\phi P_n) < 0.2, \quad (6)$$

$$\frac{P_u}{2\phi P_n} + \frac{M_{ux}}{\phi_b M_{nx}} \leq 1, \quad (7)$$

where  $P_u$  is the required axial strength and  $P_n$  is the nominal tensile or compressive strength for the member depending upon whether it is in tension or compression.  $M_{ux}$  is the required flexural strength and  $M_{nx}$  is the nominal flexural strength about the major axis of the section. The resistance factor ( $\phi$ ) is given as 0.90 in the case of tension and as 0.85 in the case of compression in LRFD.

The resistance factor for flexure  $\phi_b$  is specified as 0.90 by the same code (Hayalioglu, Saka, 1992).

Since only the nominal strengths are the functions of the depth variables, the strength constraint for member  $i$  can be re-written as:-

$$g_{sr}(D_i, D_j) = a_1 / P_n + a_2 / M_{nx}, \quad (8)$$

Where  $a_1$  and  $a_2$  are the constants given as, for

$$P_u / (\phi P_n) \geq 0.2 \quad a_1 = P_u / 0.85 \quad a_2 = 8M_u / 8.1 \quad (9)$$

$$P_u / (\phi P_n) < 0.2, \quad a_1 = P_u / 1.7 \quad a_2 = M_u / 0.9 \quad (10)$$

### **Displacement Constraint**

The  $j^{\text{th}}$  displacement constraints  $g_{dj}(D_{1i}, D_{2i})$  has the following form:-

$$g_{dj}(D_{1i}, D_{2i}) = \delta_j - \delta_{ju} \quad (11)$$

The displacement  $\delta_j$  can be expressed as a function of the depth variable by making use of the virtual work theorem

$$\delta_j = \sum_{i=1}^{nm} X_i^T K_i(D_{1i}, D_{2i}) X_{ij} \quad (12)$$

Where

$X_i$  is the vector of virtual displacements of member  $i$  due to the virtual loading corresponding to the  $j^{\text{th}}$  constrains. This is obtained by applying the unit load in the direction of the restricted displacement  $j$ .

$K(D_{1i}, D_{2i})$  is the stiffness matrix of member  $i$  in the global coordinate.

$X_i$  is the displacement vector  $e$  due to applied load.

### **Nominal Axial And Flexural Strength of Tapered Member**

It is shown from Eqs. (8) to (10) that the combined strength constraint for a tapered member makes it necessary to express the design axial and flexural strength of the member in terms of depth variables defined at its ends.

#### **Nominal tensile strength**

In the case where the tapered member is in tension, LRFD gives the nominal tensile strength  $P_n$  as ,

$$P_n = F_y \times A_g \quad (13)$$

Hence, the nominal tensile strength  $P_n$  can be expressed as a function of depth variable  $D_1$ , of the smaller end as

$$P_n = F_y (D_1 t_w + 2T) \quad (14)$$

where  $T$  is a constant given by

$$T = (t_f b_f - t_w t_f) \quad (15)$$

#### **Nominal Compressive Strength**

When the tapered member is in compression, its nominal compressive strength is given by LRFD as;

$$P_n = F_{cr} \times A_g \quad (16)$$

where  $F_{cr}$  is the critical stress computed from one of the following expressions:

$$\lambda_{eff} \leq 1.5 \quad F_{cr} = F_y (0.658^{\lambda_{eff}^2}) \quad (17)$$

$$\lambda_{eff} > 1.5 \quad F_{cr} = \frac{(0.877 F_y)}{\lambda_{eff}^2}, \quad (18)$$

$$\lambda_{eff} = S \sqrt{(Q F_y / \pi^2 E)}$$

$$\lambda_{eff} \leq 1.5 \quad P_n = (D_1 t_w + 2T) \times F_y \times 0.658^{c_1(D_1 t_w - 2T)} \quad (23)$$

$$\lambda_{eff} > 1.5 \quad P_n = (0.877 \times F_y) / c_1 \quad (24)$$

(19)

in which  $S$  is equal to  $Kl/r_{oy}$  for weak axis bending and  $Kl/r_{ox}$  for strong axis bending.  $K$  is the effective length factor for the member. Since between the adjacent lateral restraints, buckling about the weak axis governs,  $S$  is taken as  $Kl/r_{oy}$ . The approximate radius of gyration  $r_{oy}$  is defined at the smaller end of the tapered member as,

$$r_{oy} = \left[ \frac{t_f b^3 f}{6(D_1 t_w + 2T)} \right]^{1/2} \quad (20)$$

Substituting Eq. (20) into Eq. (19) and taking  $Q = 1$  gives the effective slenderness as,

$$\lambda_{eff} = [c_1(D_1 t_w + 2T)]^{1/2} \quad (21)$$

where  $c_1$  is a constant.

$$c_1 = \frac{6F_y(Kl)^2}{\pi^2 E t_f b^3 f} \quad (22)$$

Hence, the nominal compressive strength  $P_n$  of eq. (16) can be expressed in terms of depth variable  $D_i$ , at the smaller end as for :-

### **Nominal Flexural Strength**

The nominal flexural strength of tapered flexural member for the limit state of lateral torsional buckling is given in LRFD<sup>(1)</sup> as

$$M_n = (5/3) S_x F_b \quad (25)$$

$$F_b = 2/3 \left[ 1 - \frac{F_y}{12\sqrt{(F_s^2 + F_w^2)}} \right] F_y \leq 0.6F_y \quad (26)$$

Unless  $F_b \leq F_y/3$ , in which case,

$$F_b = 1.5\sqrt{(F_s^2 + F_w^2)} \quad (27)$$

In Eq (26) and (27)

$$F_s = \frac{12000A_f}{h_s l D_1}, \quad F_w = \frac{170000}{\left( \frac{h_w l}{r_{TO}} \right)^2} \quad (28)$$

Where factors  $h_s$  and  $h_w$  are given as,

$$h_s = 1 + 0.023 \gamma \sqrt{ID_i / A_f} \quad (29)$$

$$h_w = 1 + 0.00385 \gamma \sqrt{\left( \frac{l}{r_{To}} \right)} \quad (30)$$

in which  $r_{To}$  is radius of gyration of the section at the smaller end, considering only the compression flange plus 1/3 of the compression web area, taken about an axis in the plane of the web,  $A_f$  is the area of the compression flange,  $\gamma$  is given as

$$\gamma = \frac{D_2 - D_1}{D_1} \leq 0.268, (l/D_1) \text{ or } 6. \quad (31)$$

The relationships listed in eqns. (25)-(31) can be expressed in terms of depth variables at the ends of the tapered member as shown in the following. The sectional modulus  $S_x$

$$S_x = \frac{t_w(D_1 - t_f^3) + 6b_f t_f (D_2 + t_f)^2}{6D_1} \quad (32)$$

$F_s$  and  $F_w$  of Eq. (28) are written as

$$F_s = \frac{12000b_f t_f}{h_s l D_1}, \quad F_w = \frac{c_2}{c_3 h_w^2 + c_4 h_w^2 D_1} \quad (33)$$

where constants  $c_2$ ,  $c_3$  and  $c_4$  are

$$c_2 = 425,000 t_f b_f^3, \quad c_3 = 3l^2 t_f b_f, \quad c_4 = l^2 t_w \quad (34)$$

In which  $\gamma$  is function of  $D_i$  as shown in Eq. (31), and  $r_{To}$  is

$$r_{To} = \sqrt{\frac{t_f b_f^3}{4 \times (3t_f b_f + t_w D_1)}} \quad (35)$$

It is clear from Eqs. (32) to (35) that nominal flexural strength  $M_n$  can be expressed in terms of depth variables  $D_1$ , and  $D_2$ .

**Figures (2) to (5)** shows the relationships between the Nominal axial force and flexural moment strength and their derivatives with the design variables  $D_1$  &  $D_2$ . **Figures (6) and (7)** shows the relationship between the strength constrain with the design variables  $D_1$  &  $D_2$ . From these figures we can conclude that :-

1-The nominal axial tension force strength for the cross section is greater than the nominal axial compression force strength in specified depth variables  $D_1$  &  $D_2$ . This is due to the material properties for the steel which is included empirically in the equation for the nominal Strength.

2-The flexural moment strength for the section decreases with increasing the depth variable  $D_1$  but it increases with increasing the depth variable  $D_2$ . This is because that the flexural moment strength equation depends basically on the depth variable  $D_2$ .

3-The strength constrain function is slightly affected by the design variable  $D_1$  but it is strongly affected by the design variable  $D_2$ .

#### **Optimality Criteria for Depth variables**

It is shown previously that displacement and strength constraints in addition to the objective function of the optimum design problem considered is highly nonlinear function of design variables. The optimality criteria approach was found to be an effective method in finding the solution of such design problem <sup>(1, 5 and 8)</sup>. This technique transformation the constrained problem into an unconstrained one by using Lagrange multipliers. The Lagrangian of design problem is:-

$$L(D_{1i}, D_{2i}, \lambda_{dj}, \lambda_{sri}) = \sum_{i=1}^{nm} \rho_i v_i + \sum_{j=1}^{\rho} \lambda_{dj} g_{dj}(D_{1i}, D_{2i}) + \sum_{i=1}^{nm} \lambda_{sri} \cdot g_{sti}(D_{1i}, D_{2i}) \quad (36)$$

where  $\lambda_{dj}$  and  $\lambda_{sri}$  are the Lagrange multipliers for the displacement and strength constraints respectively. The necessary condition for the local constraint optimum is obtained by differentiating this equation with respect to design variables ( $D_1, D_2$ ) as follows:-

$$\frac{\partial L(D_{1i}, D_{2i}, \lambda_{dj}, \lambda_{sri})}{\partial D_{1i}} = \sum_{i=1}^{nm} \rho_i \frac{\partial v_i}{\partial D_{1i}} + \sum_{j=1}^{\rho} \lambda_{dj} \frac{\partial g_{dj}(D_{1i}, D_{2i})}{\partial D_{1i}} + \sum_{i=1}^{nm} \lambda_{sri} \cdot \frac{\partial g_{sti}(D_{1i}, D_{2i})}{\partial D_{1i}} = 0 \quad (37)$$

$$\frac{\partial L(D_{1i}, D_{2i}, \lambda_{dj}, \lambda_{sri})}{\partial D_{2i}} = \sum_{i=1}^{nm} \rho_i \frac{\partial v_i}{\partial D_{2i}} + \sum_{j=1}^{\rho} \lambda_{dj} \frac{\partial g_{dj}(D_{1i}, D_{2i})}{\partial D_{2i}} + \sum_{i=1}^{nm} \lambda_{sri} \cdot \frac{\partial g_{sti}(D_{1i}, D_{2i})}{\partial D_{2i}} = 0 \quad (38)$$

The derivative of the volume of tapered member with respect to depth variables can analytically obtained as follows :-

$$v_i = \left[ 2t_f(b_f - t_w) + \frac{(D_{1i} + D_{2i})}{2} t_w \right] l_i \quad (39)$$

$$\frac{\partial v_i}{\partial D_{1i}} = \frac{\partial v_i}{\partial D_{2i}} = \frac{1}{2} t_w l_i \quad (40)$$

The derivative of the displacement constraint from Eq. (11) becomes:-

$$\frac{\partial g_{dj}(D_{1i}, D_{2i})}{\partial D_{1i}} = \frac{\partial \delta_j}{\partial D_{1i}} \quad (41)$$

$$\frac{\partial g_{dj}(D_{1i}, D_{2i})}{\partial D_{2i}} = \frac{\partial \delta_j}{\partial D_{2i}} \quad (42)$$

Which in turn from Eq. (12) becomes:-

$$\frac{\partial \delta_j}{\partial D_{1i}} = \sum_{i=1}^{nm} X_i^T \frac{\partial K_i(D_{1i}, D_{2i})}{\partial D_{1i}} X_{ij} \quad (43)$$

$$\frac{\partial \delta_j}{\partial D_{2i}} = \sum_{i=1}^{nm} X_i^T \frac{\partial K_i(D_{1i}, D_{2i})}{\partial D_{2i}} X_{ij} \quad (44)$$

The derivatives of stiffness matrix of the tapered member can be achieved analytically in Ref.(3 ).

On the other hand the , the same can also be achieved for the derivative of the strength constraints with respect to design variables( $D_1, D_2$ ) as follows:-

$$\frac{\partial g_{sri}(D_{1i}, D_{2i})}{\partial D_{1i}} = -\frac{a_1(\frac{\partial P_n}{\partial D_{1i}})}{P_n^2} - \frac{a_1(\frac{\partial M_n}{\partial D_{1i}})}{M_n^2} \tag{45}$$

$$\frac{\partial g_{sri}(D_{1i}, D_{2i})}{\partial D_{2i}} = -\frac{a_1(\frac{\partial P_n}{\partial D_{2i}})}{P_n^2} - \frac{a_2(\frac{\partial M_n}{\partial D_{2i}})}{M_n^2} \tag{46}$$

The derivatives  $(\frac{\partial P_n}{\partial D_j})$  and  $(\frac{\partial M_n}{\partial D_j})$  can be achieved using numerical technique (finite difference technique) as follows;-

$$\frac{\partial P_n}{\partial D_{1i}} = \frac{\Delta P_n}{\Delta D_{1i}} = \frac{P_{n2} - P_{n1}}{D_{1i2} - D_{1i1}}, \quad \frac{\partial M_n}{\partial D_{1i}} = \frac{\Delta M_n}{\Delta D_{1i}} = \frac{M_{n2} - M_{n1}}{D_{1i2} - D_{1i1}} \tag{47}$$

$$\frac{\partial P_n}{\partial D_{2i}} = \frac{\Delta P_n}{\Delta D_{2i}} = \frac{P_{n2} - P_{n1}}{D_{2i2} - D_{2i1}}, \quad \frac{\partial M_n}{\partial D_{2i}} = \frac{\Delta M_n}{\Delta D_{2i}} = \frac{M_{n2} - M_{n1}}{D_{2i2} - D_{2i1}} \tag{48}$$

Hence the optimality criteria for depth variables are obtained from Equation (37) and (38) as follows:-

$$\frac{\partial L(D_1, D_2, \lambda_{dj}, \lambda_{sri})}{\partial D_{1i}} = \sum_{i=1}^{mm} \rho_i \frac{\partial v_i}{\partial D_{1i}} + \sum_{j=1}^{\rho} \lambda_{dj} \times \sum_{i=1}^{mm} X_i^T \frac{\partial K_i(D_{1i}, D_{2i})}{\partial D_{1i}} X_{ij} + \sum_{i=1}^{mm} \lambda_{sri} \times \left( -\frac{a_1(\frac{\partial P_n}{\partial D_{1i}})}{P_n^2} - \frac{a_1(\frac{\partial M_n}{\partial D_{1i}})}{M_n^2} \right) = 0 \tag{49}$$

which lead to:-

$$\frac{\left[ \sum_{j=1}^{\rho} \lambda_{dj} \times \sum_{i=1}^{mm} X_i^T \frac{\partial K_i(D_{1i}, D_{2i})}{\partial D_{1i}} X_{ij} + \sum_{i=1}^{mm} \lambda_{sri} \times \left( -\frac{a_1(\frac{\partial P_n}{\partial D_{1i}})}{P_n^2} - \frac{a_1(\frac{\partial M_n}{\partial D_{1i}})}{M_n^2} \right) \right]}{\sum_{i=1}^{mm} \rho_i \frac{\partial v_i}{\partial D_{1i}}} = 1 \tag{50}$$

And

$$\frac{\partial L(D_1, D_2, \lambda_{dj}, \lambda_{sri})}{\partial D_{2i}} = \sum_{i=1}^{mm} \rho_i \frac{\partial v_i}{\partial D_{2i}} + \sum_{j=1}^{\rho} \lambda_{dj} \times \sum_{i=1}^{mm} X_i^T \frac{\partial K_i(D_{2i}, D_{2i})}{\partial D_{2i}} X_{ij} + \sum_{i=1}^{mm} \lambda_{sri} \times \left( -\frac{a_1(\frac{\partial P_n}{\partial D_{2i}})}{P_n^2} - \frac{a_2(\frac{\partial M_n}{\partial D_{2i}})}{M_n^2} \right) = 0 \tag{51}$$

which lead to:-

$$\frac{\left[ \sum_{j=1}^{\rho} \lambda_{dj} \times \sum_{i=1}^{mm} X_i^T \frac{\partial K_i(D_{1i}, D_{2i})}{\partial D_{2i}} X_{ij} + \sum_{i=1}^{mm} \lambda_{sri} \times \left( -\frac{a_1(\frac{\partial P_n}{\partial D_{2i}})}{P_n^2} - \frac{a_2(\frac{\partial M_n}{\partial D_{2i}})}{M_n^2} \right) \right]}{\sum_{i=1}^{mm} \rho_i \frac{\partial v_i}{\partial D_{2i}}} = 1 \tag{52}$$



Multiplying both sides of Equations (52) and (54) by  $D_{1i}^c$  and  $D_{2i}^c$ , respectively, and then taking the  $c^{th}$  root yields:-

$$D_{1i}^{t+1} = D_{1i}^t \times \left[ \frac{\left[ \sum_{j=1}^{\rho} \lambda_{dj} \times \sum_{i=1}^{nm} X_i^T \frac{\partial K_i(D_{1i}, D_{1i})}{\partial D_{1i}} X_{ij} + \sum_{i=1}^{nm} \lambda_{sri} \times \left( -\frac{a_1(\partial P_n / \partial D_{1i})}{P_n^2} - \frac{a_1(\partial M_n / \partial D_{1i})}{M_n^2} \right) \right]^{\frac{1}{c}}}{\sum_{i=1}^{nm} \rho_i \frac{\partial v_i}{\partial D_{1i}}} \right]^c \quad (53)$$

$$D_{2i}^{t+1} = D_{2i}^t \times \left[ \frac{\left[ \sum_{j=1}^{\rho} \lambda_{dj} \times \sum_{i=1}^{nm} X_i^T \frac{\partial K_i(D_{1i}, D_{2i})}{\partial D_{2i}} X_{ij} + \sum_{i=1}^{nm} \lambda_{sri} \times \left( -\frac{a_1(\partial P_n / \partial D_{2i})}{P_n^2} - \frac{a_2(\partial M_n / \partial D_{2i})}{M_n^2} \right) \right]^{\frac{1}{c}}}{\sum_{i=1}^{nm} \rho_i \frac{\partial v_i}{\partial D_{2i}}} \right]^c \quad (54)$$

where

$t$  and  $t+1$  represent the current and the following optimum design cycles, and the  $c$  is known as the step size process.

It is apparent that the use of Equation. (53) and (54) require that values of Lagrange multipliers to be known. There are several methods to obtain their values. One simple and effective way used in Ref.(1). This method takes the constraint equality and multiplies both sides by  $\lambda_{dj}^m$  and then takes the  $m^{th}$  root. This leads to the following recursive relationship :-

$$\lambda_{dj}^r = \lambda_j^{r+1} \cdot \left( \frac{\delta_j}{\delta_{ju}} \right)^{\frac{1}{m}} \quad j=1, 2, \text{eq. } \rho \quad (55)$$

where  $m$  is the step size and its value from the numerical examples is between 0.8 and 0.7 for  $\frac{1}{m}$ . It is clear that Eqs. (54) and (55) require the initial values of the Lagrange parameters to be selected. It was found suitable to use (10000) as an initial value for these parameters (multipliers).

**Figures (8) and (9)** shows the relationships between the derivatives of the strength constraints with the design variables  $D_1$  &  $D_2$ .

From these figures we can conclude that :-

1-for the value of  $\frac{P_u}{P_n} < 0.2$ , the derivative of strength constraints for the cross section is slightly greater in compression than in the tension force with respect to design variables  $D_1$  &  $D_2$ .

2- for the value of  $\frac{P_u}{P_n} \geq 0.2$  the derivative of strength constraints for the cross section is slightly greater in tension than in the compression force with respect to design variables  $D_1$ .

### **Nonlinear Elastic Analysis of Steel Frames Composed of Tapered Members.**

The nonlinear elastic analysis of frames composed from tapered members is obtained by the method reported in Ref.(3) .This method improved from the nonlinear elastic analysis of frames composed of prismatic members described in Ref.(7) which takes into account both the geometrical and material nonlinearities .

#### **Design Convergence Criteria:-**

Two types of design criteria are use in this study to insurance the satisfaction of the convergence in design, these are :-

**1-weight criteria:** This criterion depends on comparison of the weight of the frame for the current design cycle and the weight of the frame for the previous design cycle, and convergence is assumed to have occurred when the inequality :-

$$(W_{r+1} - W_r)^2 / W_r^2 \leq tol_1 \text{ is satisfied} \quad (56)$$

Where: -  $W_{r+1}$ : represents the total weight of the structure in the current design cycle

$W_r$  : represents the total weight of the structure in previous design cycle

**2-depth criteria :-** This criterion depends on comparison of the depth at both ends of each design group of the frame for the current design cycle and for the previous design cycle, and convergence is assumed to have occurred when the inequality when the inequality

$$(D_{i+1} - D_i) / D_i \leq tol_2 \quad (57)$$

In Eq. (56 ) and (57 ), the dimensionless quantity, **tol**. represents a prescribed tolerance each criteria In this study the tolerance used as indication for satisfied the convergence is as follows

**tol1= 0.005. tol2= .01**

#### **Flow chart and computer program:-**

The algorithm developed for optimum design of geometrical nonlinear elastic –frame composed of tapered members can be described by the following chart of the program with a brief description for each subroutine, **Fig.(10)** and a computer program (EDTS) is developed using QBasic language. .

#### **Design Examples**

Two examples are used her to demonstrate the capability of the algorithm developed in this study to achieve the optimum design of tapered steel frame under elastic nonlinear behavior , the values of modulus of elasticity and yield strength of the steel used to fabricate the structure were taken as 205 kN/mm<sup>2</sup> and 275N/mm<sup>2</sup> respectively .The density of the steel was 7850kg/m<sup>3</sup>.Th convergence criteria used for the minimum objective function was 0.1% while it was 1% for the depth variables

##### **1-Fixed Ends Tapered Beam.**

In this example a single span beam was designed using the algorithm developed in this study , the dimensions of the beam ,member cross section and loading condition is shows in **Fig. (11)** the beam was divided into two linearly tapered beams which introduced two design variables in each beam (1,2)in beam No.1 and (2,3)in beam No.2 , due to symmetry the depths and nodes 1 & 3 was assumed to be the same . This would eliminate the design variables into two variables ( $D_1$ &  $D_2$ ), the frames was designed under three cases of constraints

1-Displacement constraints

2-Strength constraints.

3-Both displacements & strength constraints.

The results of both studies is shown in **Figs.(12 to14)** It shows from these figures that the reduction in depth variable  $D_2$  is more faster than in depth variable  $D_1$  which mean that the value of depth variable  $D_2$  more effective in the optimum design processes from the value of  $D_1$  this may be caused by the including of the geometrical nonlinearity in the analysis and taking in the account the large deformation, bowing effect and stability behavior of the structure which lead to increasing the

effect of design components relating to depth variable  $D_2$  on the other hand the depth variable  $D_2$  usually used in maximum flexural moment zone which is usually near the support so that the deformations and displacement is being at their maximum value and then cause that increase in optimum design components.

From figures (12-14) we can note that when excluding the displacement constraints from the optimum design processes the decreasing in depth variables  $D_1$  &  $D_2$  become more that when using both displacements and strength constraints and which lead to lighter structure and subsequently more economic and more save in cost without increase in the constrained displacement on its upper bound. This mean that including the strength constraints in the optimum design processes will improve the design efficiently. On the other hand the optimum design reached after design cycle No.8 we using strength constraints only in the optimum design comparing with design cycle No.9 when including both displacement and strength constraints.

### **2-Pitched roof tapered steel frame.**

In the example a one bay pitch roof frame is designed using the optimum design algorithm developed her, the frame is divided to 15 node at the point of application the external loads and 14 tapered member, the dimension of the frame, member cross section and loading condition is shows in **Fig.(15)**. This frame was designed by Ref. (5) using linear elastic analysis, in this study the frame is designed three constraints cases :-

- 1-Displacement constraints
- 2-Strength constraints.
- 3-Both displacements & strength constraints.

The results of our study is shown in Figures (16 to 19), from these figures we reach to the same view obtained from the previous example in addition to noting that in this example we have two design groups the rafters (Beams) and the columns, each group treated separately in design processes but at the joints the developed program takes into account the effect of changing in each depth variable on the connected members which help in giving more reliable design. The results of design for each group are shown separately in figures (16) and (17) we can note the similarity in behavior for each group. the effect of nonlinear analysis is shown obviously in **Fig.(19)** hence from this Figure we can observe that the displacement reached to its upper limit faster than the former example.

### **Conclusions:-**

Depending on the design results obtained from the present study, one can draw several conclusions, concerning the optimum design of the tapered steel frames with I-section these may be summarized as follows: -

- 1-The optimum design components represented in this study by the strength and displacement constraints equations is affected by the design variable  $D_2$ , specially when including the geometrical nonlinearity and stability behaviors in the analysis of steel frame. This is required to choose the value of depth variable  $D_2$  carefully in design of such frames.
- 2- The excluding of displacement constraints in the optimum design processes( using strength constraints only )lead to faster design and more economic and saving in cost design .
- 3-In frames composed from different structural members, the behavior of the optimum design results will be slightly different.
- 4- This study may be improved by including more restrains in to design processes that make the design more economic and more saving in time and cost such as (buckling constraint, plasticity constraint, creep constraint)

## References

- 1- Hayalioglu, M. S. and Saka, M. P., " *Optimum Design of Geometrically Nonlinear Elastic-Plastic Steel Frames With Tapered Members*", *Inter. Jour. of Compu. And Struc.* Vol.44, No.4,1992, pp.915-924.
- 2- Haitham A. Bady, " *Nonlinear Elastic-Plastic Instability Analysis of Frames with Nonprismatic Members*", *MSc. Thesis, University of Technology/building and Construction Department, 2000.*
- 3-Haitham A. Bady," *Optimum Design of Nonlinear Elastic-Plastic Steel Frames Composed From Non-prismatic Members with Displacement Constraints*"", *Jour. of Babylon University, Vol. 13, No.5, 2005.*
- 4-*Load and Resisting Factored Design* ,Specification for Structural Steel Build, AISC, U.S.A, 2000.
- 5- M.P.Saka," *Optimum Design Of Steel Frame with Tapered Members*" *J. Computer &Structures, Vol.63, No.4, PP.797-811, 1997.*
- 6-M.P.Saka."*Optimum Design Of Steel Frames With Stability Constraints*" *J. Computer & Structures, Vol.41, PP.1365-1277, 1991.*
- 7- Oran, C., " *Geometric Nonlinearity in Nonprismatic Members*", *Jour. of the Stru. Div., ASCE, Vol. 100, No. ST7, July, 1974, pp.1473-1487.*
- 8- Raphael.T.Haftka and Zfer Gurdal "*Element Structural Optimizations*" , *Solid Mechanics and its Applications* , *mKluwer Academic Puplishers,1993*
- 9-Tam, T. K. H. and Jennings, A., " *Optimal Elastic Design of Frames with Tapered Members*" , *Inter. Jour. of Computers and Structures, Vol. 30, No.3, 1988, pp.537-544.*

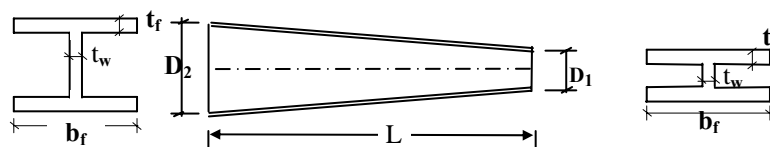

Fig. (1): Typical Tapered Member With Linear Variation

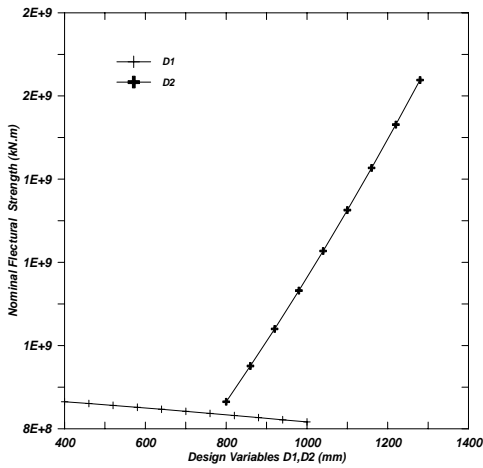

Fig.(2): Relationship between Design variables D1 & D2 and the Nominal Flexural Strength  $M_n$

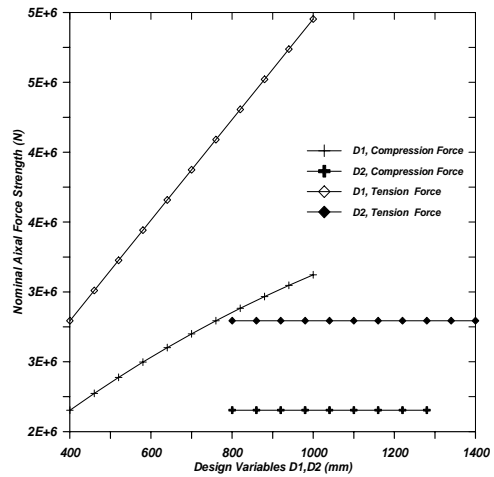

Fig.(3): Relationship between Design variables D1 & D2 and the Nominal Axial Force Strength  $P_n$

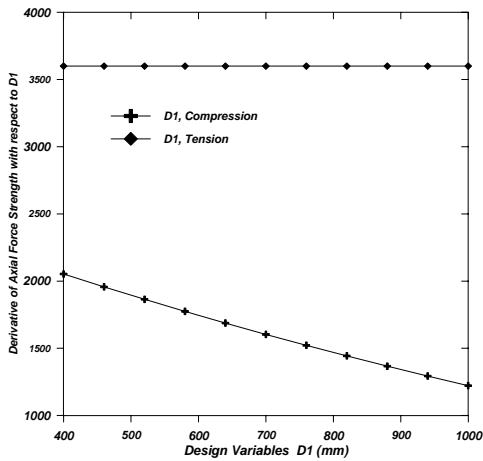

Fig.(4): Relationship between Design variable D1 and the Derivatives of Nominal Axial Force Strength  $P_n$  with respect to D1

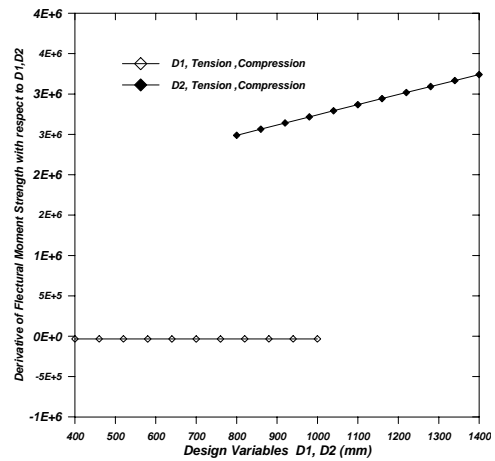

Fig.(5): Relationship between Design variables D1 & D2 and the Derivatives of Nominal Flexural Strength  $M_n$  with respect to D1&D2

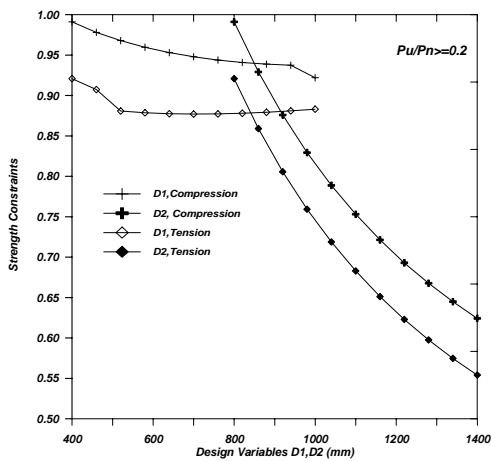

Fig.(6): Relationship between Design variable D1 and the Strength Constraints

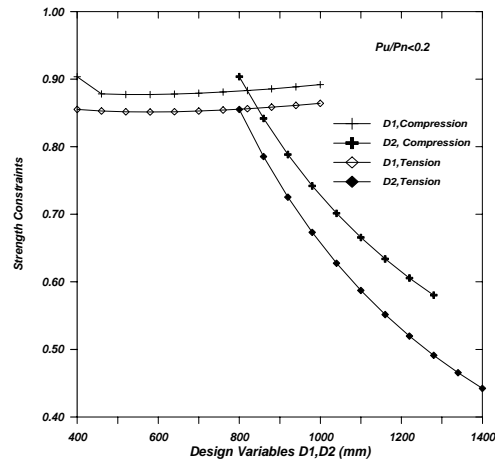
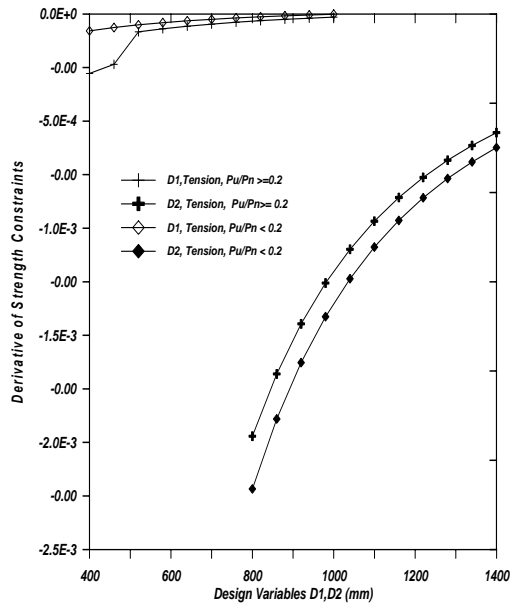
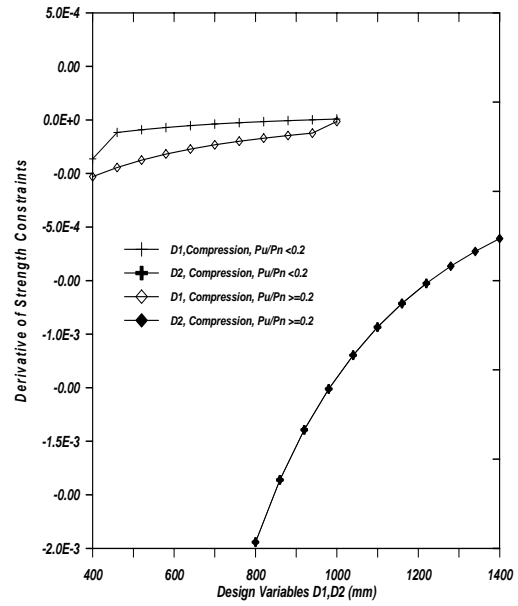

Fig.(7): Relationship between Design variable D1 and the Strength Constraints



**Fig.(8): Relationship between Design variable D1 &D2 and the Derivatives of Strength Constraints in the case of tension force**



**Fig.(9): Relationship between Design variable D1 &D2 and the Derivatives of Strength Constraints in the case of compression force**

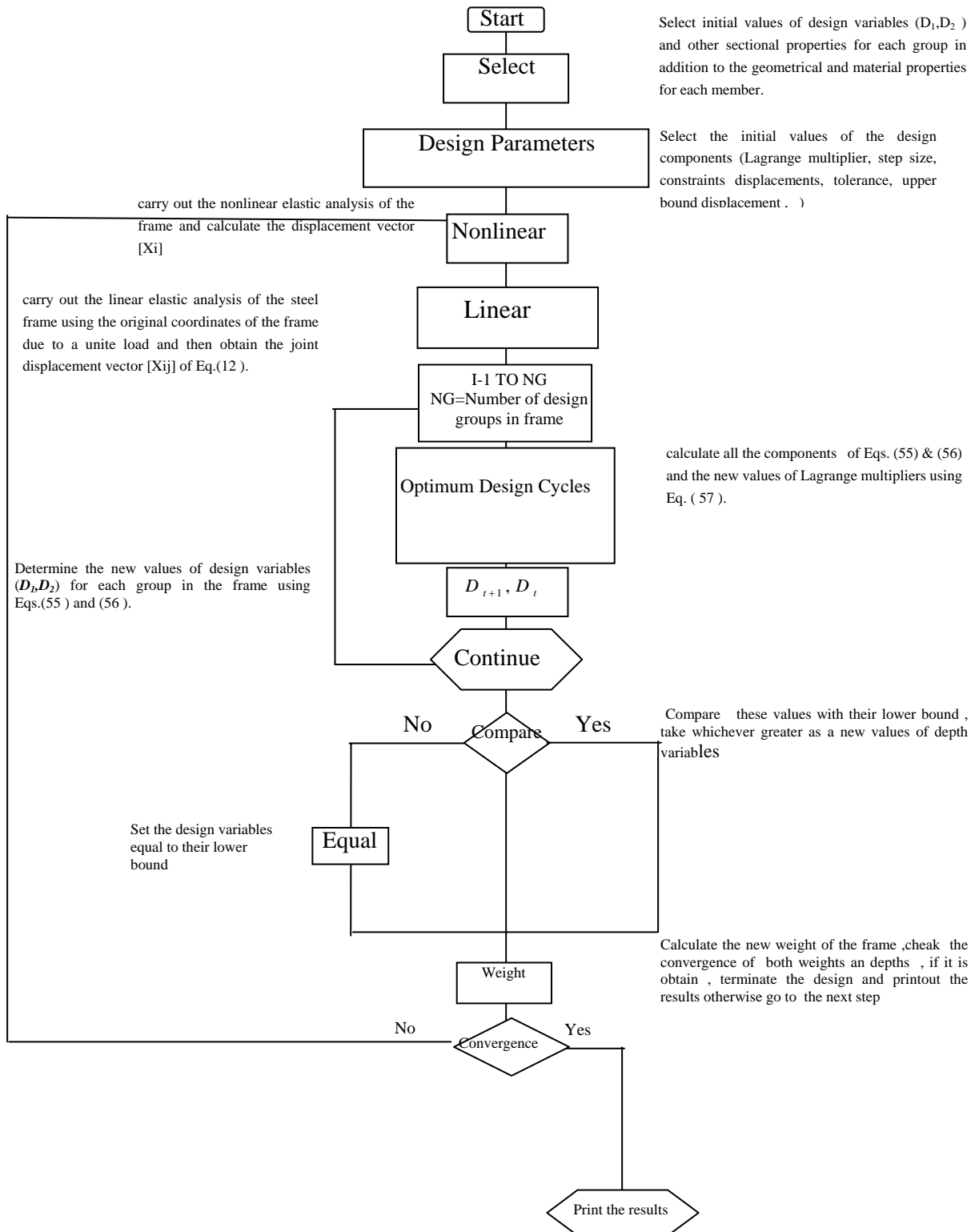

Fig. (10) Flow Chart of the Computer Program (EDTS)

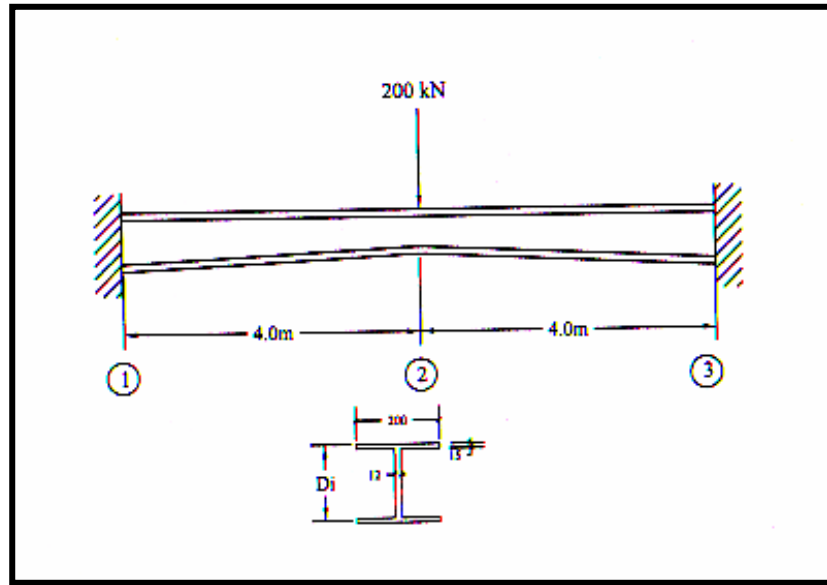

Fig.(11): Fixed Ends Tapered Beam.

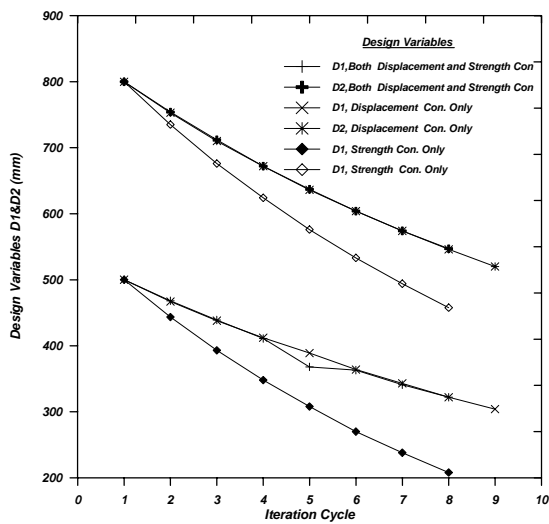

Fig.(12): Relationships Between the Iteration Cycles and the Design variables D1 & D2

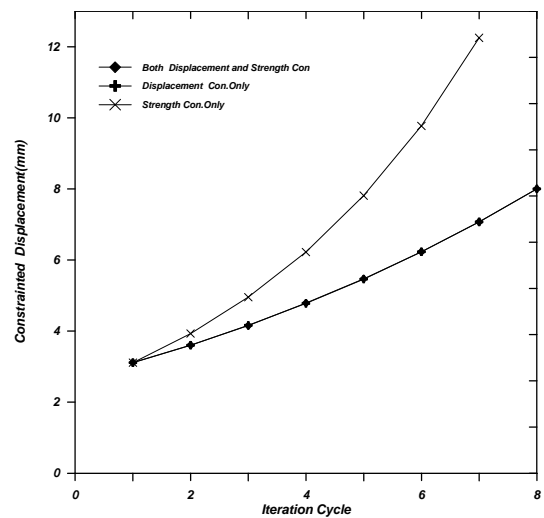

Fig.(13): Relationships Between the Iteration Cycles and Constrained Displacement

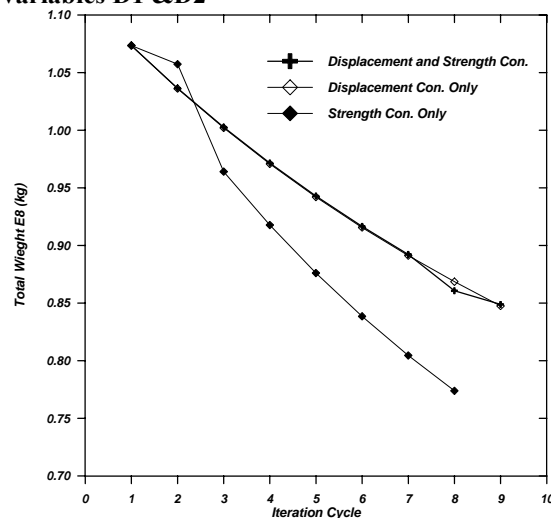
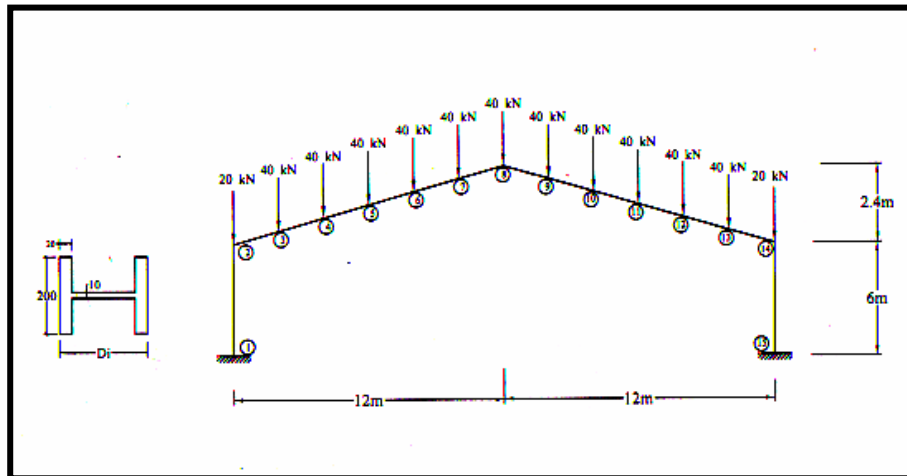

Fig.(14): Relationships Between the Iteration Cycles and Total Weight of the Beam





Fig(15): Pitched Roof Fixed Ends Steel Frame

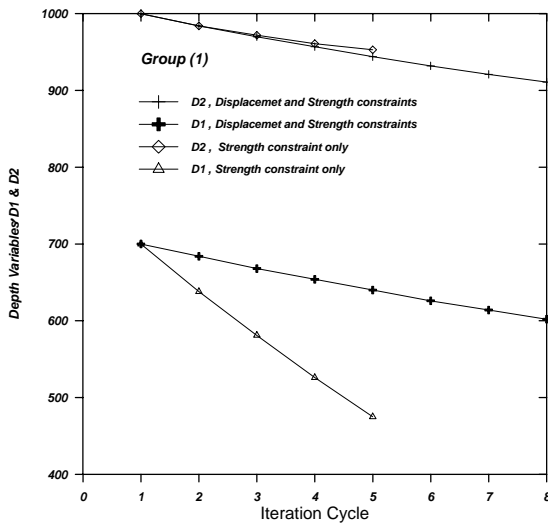

Fig.(16): Relationships Between the Iteration Cycles and Depth Variables D1&D2 for Rafters

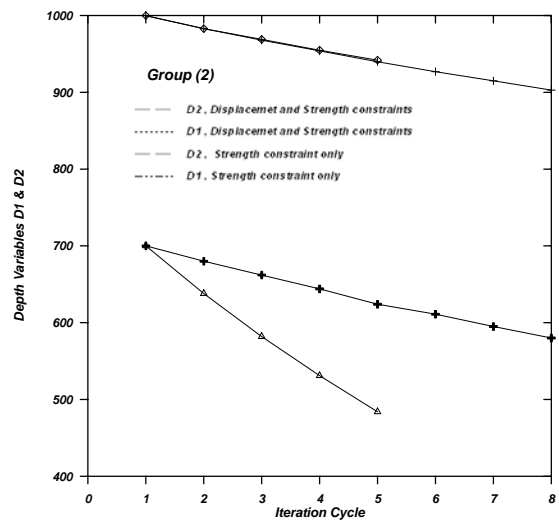

Fig.(17): Relationships Between the Iteration Cycles and Depth Variables D1&D2 D2 for Columns

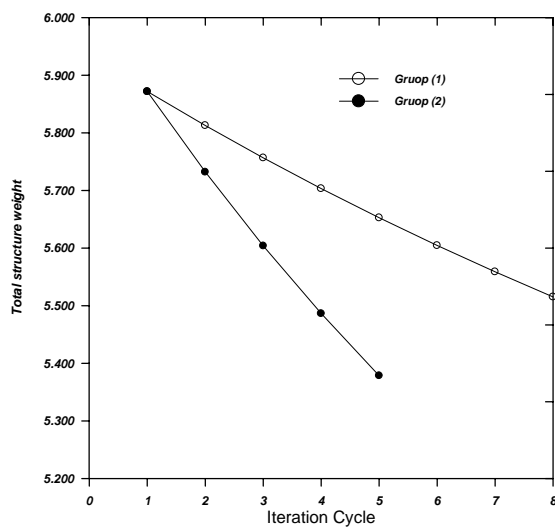

Fig.(18): Relationships Between the Iteration Cycles and Total Weight of the Frame

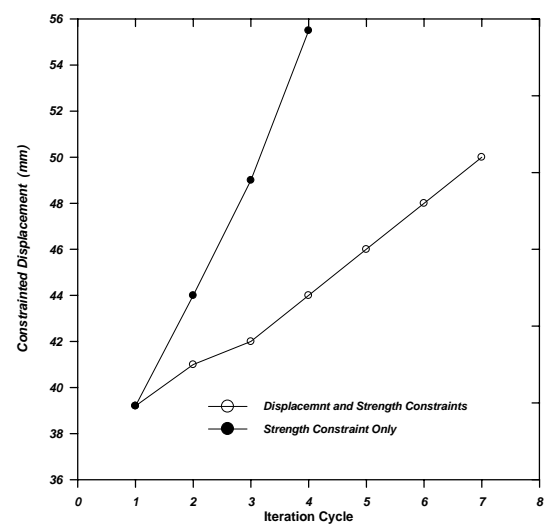

Fig.(19): Relationships Between the Iteration Cycles and the Constrained Displacements