

Study on the Mechanical Properties and the Matching of Bolt Components

Xiaowen Wang

Weifang Science and Technology University, Shouguang 262700, China
 wangxiaowen@126.com

The roadway has to adapt to the surrounding rock movement compensation tracking anchoring force changes, strong anchor bolt, lightweight and Recyclable reuse, the advantages of economy and environmental protection. Compared with the traditional bolt and rock is prone to lack of cohesion, not suitable for supporting or prone to large deformation of roadway in soft rock, the anchoring force of unstable phenomenon. Therefore, it is of great theoretical significance and practical value to study the bolt of roadway. This topic is based on the. In this paper, starting from the ground experimental roadway bolt, combined with elastic-plastic mechanics, rock mechanics theory, using finite element contact analysis of roadway bolt, provide a theoretical basis for the design and production of the bolt, and the simulation results with the theoretical and numerical results are verified by the numerical test on the ratio, improved model and lay the foundation for optimization of bolt structure. The mechanical properties and influencing factors of resin anchoring agent were studied. The results show that the bolt is in a normal state when the bolt is subjected to tension, bending, torsion, shear and its combination, and the 4 position of the rod is easy to break. The stress distribution of the surface and the near part of the thread is changed significantly, and the stress concentration is obvious at the bottom of the thread. 5 stages can be divided into arch plate deformation; arch height must meet in order to ensure sufficient bearing capacity to a certain value. The geometry, the parameters and the mechanical properties of the bolt end member should match each other, so that the anchor rod is in a good state of stress. The resin anchoring agent should be matched with the rod body and the hole to ensure the good bonding property between the anchor rod anchoring agent and the anchoring agent. The research results have been applied to many kinds of difficult roadway, which greatly reduced the damage of the bolt support and significantly improved the effect of roadway support.

1. Introduction

As the object of geotechnical engineering facing the complex geological body, in the long geological ages, due to experiencing tectonic movement, natural weathering erosion and human activity, resulting in large amounts such as bedding, fault, joint and weak interlayer, solution groove, solution groove etc. kinds of geological defects. Within a certain period of time and under certain conditions, they may be in a relatively stable state of equilibrium. If conditions change, the original balance state is likely to be destroyed, for example in the process of excavation in geotechnical engineering geologic body, the original balance is broken, the original stress field redistribution, which occurred in the rock and soil deformation, causing landslides, collapse and landslide, rock collapse, ground subsidence and other geological disasters. In order to prevent and control this kind of geological disaster, all kinds of support came into being. Bolt supporting is a tension member embedded in rock and soil, the structure and formation of chain tightly together, so that the surrounding rock from passive to active load bearing, arouse the rock and soil itself strength and stability. This is called the anchor rod (Kang et al., 2015). Therefore, the bolt has a good development prospect. Therefore, the research of this subject has important academic significance and engineering significance, at the same time, it has good economic and social benefits. In this paper, the influence of structural parameters on the performance of the flexible compression anchor is studied through three aspects: analytical analysis, numerical simulation and experiment. Nowadays, the bolt supporting technology has entered the stage of high strength pressurised anchor system. With the stress based bolting design method gradually mature, high strength and length of bolt

supporting system has been widely used in engineering construction, and has become the symbol of this stage, at the same time in order to realize the detection of rock dynamic, developing instrument of roof separation and force anchor rod and other equipment, to realize the objective to provide technical support means. It is considered that the function of the bolt support is to hang the roof of the tunnel to the upper stable rock layer, although the theory is easy to understand, there are many defects. Usually when calculating the anchoring force of anchor bolt that is equal to the lower suspension rock weight, but this phenomenon exists only in loose rock or unstable strata completely out of the stable rock, which is rare (Kan and Qian, 2016). Although the suspension theory can explain the bolt in hard rock exists in the anchorage area in the case of the supporting role, but in the soft rock roadway in soft rock roadway, especially when the span is large, the rock high natural arch will generally be greater than the length of the anchor, in this case, the success of rock bolt support and reinforcement, reasonable explanation of the suspension theory. In conclusion, suspension theory only take into account the effect of bolt tensile, shear capacity for rock bolt reinforcement, improving the overall strength of the rock bolt is not involved, so the load calculated with actual numerical difference, suspension function diagram as shown in Figure 1, on the one hand the layers are squeezed two contact surface pressure makes the friction between the two layers increased, the frictional resistance and the positioning bolt can prevent the anchorage system in rock sliding along the level, thereby avoiding the phenomenon of layered rock; on the other hand, the multilayer rock bolt as a whole, so that the shear stiffness increase in order to prevent the generation of surrounding rock, strata horizontal dislocation. At the same time, the stress and deflection of each layer are greatly reduced under the overburden rock, so the bending strength of the composite beam is increased. The bolt embedded in rock and soil depth, the equivalent of the simple superposition of several layers of beam into composite beam, composite beam inside the thicker the, maximum stress, strain and deflection is small, and the bearing capacity of beams is bigger. The greater the anchoring force of the anchor, the greater the friction resistance between the rock layers, the higher the degree of integration of the composite beam, the greater the intensity of the composite beam schematic diagram shown in Figure 2.

The maximum horizontal stress is considered that the deformation of the surrounding rock is caused by the maximum horizontal stress and the shear resistance of the rock, which results in the dislocation or looseness of the rock. And the bolt in the surrounding rock is to limit the limit of the roof and floor rock due to the expansion of the axial movement and the shear stress due to the axial and vertical dislocation. So the bolt material must be selected with high shear resistance, high rigidity and high strength, the only way to play the role of constraints of surrounding rock deformation (Li et al., 2015).

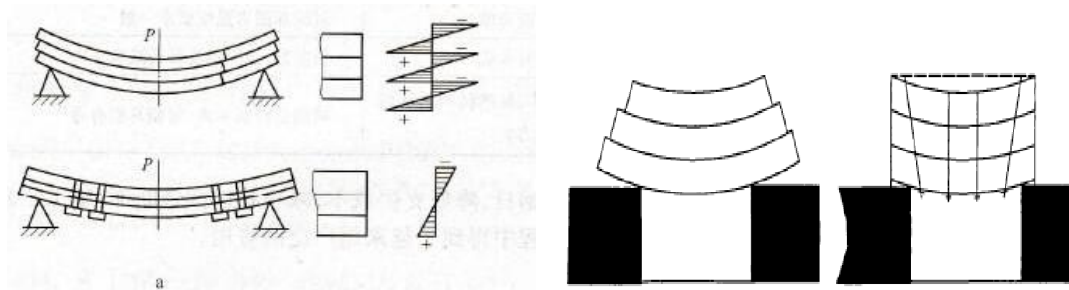

Figure 1: Schematic diagram of suspension effect Figure 2: Schematic diagram of composite beam

2. Down whole test and finite element contact analysis of anchor member

2.1 Introduction to underground test of anchor member

The bolt ends are respectively arranged in the hole of rock (coal hole) and simulated pipe, placed tight, there is no exposed part, and then to anchor the cavity filling air or hydraulic pressure, tensile test of drawing bolt Jack power. The hollow jack loading equipment, drawing stroke range for 0~30t, 0~50mm, used as indicator measuring equipment, pressure gauge range for 0~16MPa.

At the end of filling pressure, anchor cavity pressure stability, the flexible pressurized anchor pull-out force applied, anti-drawing performance of ground test, by pressing the drawing jack handle, the top rod, bolt tension began, over a period of time to check and record Jack external pressure gauge and dial indicator measuring numerical tensile length to anchor, until the bolt failure or slippage. In order to investigate the influence of internal pressure on the allowable drawing load of bolt, the pressure value of internal pressure can be recorded at the time of injection. When the anchor shear performance of the ground test, by pressing the jack handle, the jack bolt rod, slow shear, over a period of time to check and record the pressure gauge and

Jack external value by the dial indicator to get the shear displacement of anchor, anchor until failure or slippage. According to the experimental results of the tensile force of the anchor bolt, the tensile force of the bolt is approximately linear with the injection pressure in the anchor bolt (Chou and Zhao, 2015). Through the test of bolt tensile force and the shear stress of the anti-load performance can satisfy the need of engineering anchor; flexible tensile load injection bolt and shear load will increase with the injection pressure increasing, however, the change of internal pressure, tensile anchor rod the sensitivity values change greatly and the shear resistance of relatively small changes in a short time; for the underground work, the anchor bolt sealing performance and the long-term capacity to meet the basic engineering needs. The anchor rod selection of materials with flame retardancy, antistatic properties, aging resistance, in order to meet the underground safety performance requirements, the cost of resin bolt with same specifications and the length of plastic anchor roughly (Gao and Li, 2016; Su, 2016). Figure 3 shows schematic diagram of down whole test results.

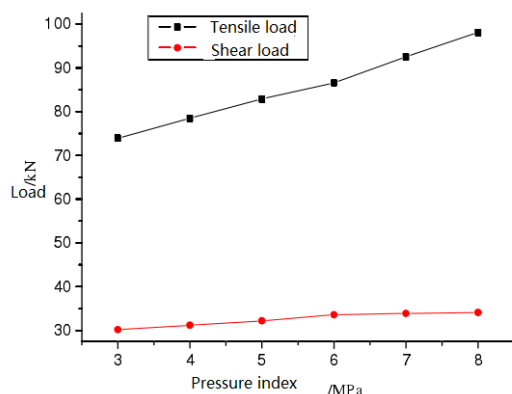

Figure 3: Schematic diagram of down whole test results.

2.2 The establishment of the mathematical model of bolt anchorage system

Under the ideal working condition, the axial tensile stress of the bolt body is equal to the longitudinal tensile stress of the bolt. So we can ignore the secondary factors that of longitudinal stress has little influence, such as radial constraint on bolt and rock wall friction (the friction is part of the dangerous section to the anchor head end part of the surrounding rock and bolt body no sliding or sliding trend), gas or liquid on the inner wall of the radial pressure. At this time the anchor forces balance. Therefore P and by drawing load injection in the internal pressure of P produced in the dangerous section and equal to the longitudinal reinforced polymer material with high strength steel wire and anchor rod body layer of tension and, in short, the total force shared by high strength steel wire and polymer materials. The longitudinal reinforcement layer of steel material, main bearing drawing force to the longitudinal (or axial) enhanced transverse on the polymer rod body and rock anchor hole (or radial) extrusion effect negligible; sealing layer is made of rubber materials for injection pressure, and the pressure to the contact surface to the ring; the fixed length enhancement layer material for fiber (such as nylon, nylon), to limit the effect of bolt diameter, only when the bolt reaches the limit when the size of the ring to be fixed layer, wear-resistant bearing layer materials for rubber, mainly used to bear the pressure of bolt hole wall between the wall and the anchor, and provide enough friction for the anchorage system. The anchor wall as internal boundary under uniform internal pressure injection effect of p ; as the anchor wall mechanics model of the outer boundary, only consider the surrounding rock anchor hole wall is far away from the rigid body and the distance of rock hole wall stress is zero this two typical situations. The following two cases were solved (Wang, 2016). The anchor body under shear stress refers to shear between the steel wire and rod polymer materials stress, because the analysis is complicated to calculate the shear stress, so the engineering calculation assumptions. In order to simulate the stress and working state of the bolt in rock mass more accurately, the 3D modelling is chosen. The structure of the flexible grouting anchor rod is shown in figure 4. In order to solve the load increment and gradually increasing load but, unfortunately, this method will be the inevitable error of each step with the cumulative increase, and the final results and for far, unable to achieve the balance (Luo et al., 2015).

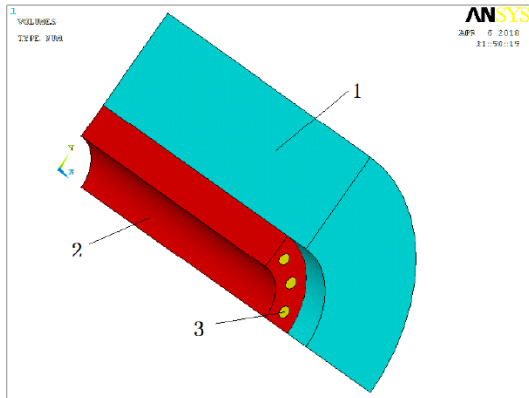

Figure 4: Schematic diagram of the structure of flexible grouting anchor rod.

2.3 Basic theory of contact analysis

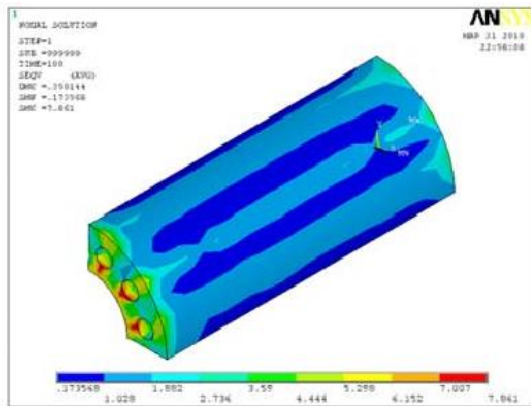

Figure 5: Schematic diagram of the bearing force of bolt and surrounding rock.

ANSYS nonlinear solution can be divided into three levels: load step, sub step and equilibrium iteration. In order to obtain the convergence of the solution procedure not sub steps will conduct a series of equilibrium iteration, in each step, the control program execution sub step (or time step) complete step-by-step loading; the top level refers to those in a "time" within the defined load step, can assume these loads in the load step is linear change. Because the surrounding rock the gravel rock anchor rod for polymer materials, so the contact problem of flexible pressurized anchor and surrounding rock is assumed to be flexible contact type flexible body, more in line with the actual situation. According to the mechanical model of the anchorage system, it can be seen that the deformation of the surrounding rock mass and the bolt body will be affected by the pressure and the surrounding rock pressure (Gong et al., 2016). Therefore, we need to discuss the distribution of the contact stress, the stress of the bolt and surrounding rock, and the distribution of the displacement of the anchor. As shown in Figure 5, the bolt body, the contact edge of polymer material and steel wire on the maximum equivalent stress, equivalent stress is 7.862MPa; the minimum occurs at the edge of polymer materials and close to the anchor hole in between two steel, 0.173MPa. The reason for the maximum stress is due to the sudden change of the material on the contact edge of the steel wire and the polymer material. It can be seen that the stress of the polymer material near the wire is worse than that of the steel wire, and the stress value of the polymer material near the wire is much higher than that of the steel wire. Correspondingly, the stress on the inner wall of the anchor body is much higher than that of the outer wall. Therefore, the equivalent stress of the bolt body is related to the diameter of the steel wire and the quantity of the steel wire. In order to study the influence of various structural parameters on the anchoring system, only one set of parameters is chosen to study the data. Keeping the other parameters unchanged, the data are classified according to the type of the parameters, and the influence of the parameters on the anchoring system is obtained. No matter the anchor of the longitudinal reinforcement layer select wire strengthened with increasing the elastic modulus of polymer materials, the surrounding rock and the maximum equivalent stress of bolt anchorage system, maximum contact stress is reduced, but the bolt body decreases the maximum equivalent

stress amplitude is not obvious. Therefore, in order to play a good anchorage effect of the surrounding rock should be in the material to meet the strength requirements of the premise of the selection of small elastic modulus of the material to make the body. As the injection pressure increases, the three group of anchor rod the maximum equivalent stress of surrounding rock, the maximum equivalent should be the same trends and anchorage system of the maximum contact stress, increases, and a linear increase, but the increasing rate is different, the maximum equivalent stress of anchor bolt internal pressure changes were more sensitive therefore, in order to enhance the anchoring effect and increase in injection pressure should pay special attention to strength bolt body.

3. Influence of structural parameters of bolt member on allowable drawing load

When the anchor bolt is installed, in order to prevent the anchor bolt from being pulled out of the anchor hole, the surrounding rock at the end of the anchor bolt must be provided with enough pulling force. Therefore, it is necessary to get the allowable drawing load of the anchor bolt, so that the pulling force of the anchor bolt is under the secondary strength, so as to ensure the normal operation of the anchor rod. Considering the physical structure is more complex, the difficulty in modelling the finite element simulation and the local material and shape change of the paper is not affected, so the bolt is simplified as a polymer material with steel wire reinforced body cavity. According to symmetry, select anchor section 1/4 finite element model is established, and according to the characteristics of plane strain and need the three-dimensional display, select the middle part of the bolt body is smaller than the original length as the research object, the model shown in Figure 6 the simplified. After the physical model is built, the SOLID186 with the intermediate node is chosen as the unit type of the model. When the mesh is divided, the nodes on the contact surface of different materials are taken into account, so the finite element method is used to divide the mesh, so as to ensure the smooth calculation. Due to the overall size of the longitudinal reinforcement layer is less than the surrounding rock, the number of qualified units should be increased. Because of the nonlinear problem, the mesh can be guaranteed to be accurate enough. The Hex/Wedge method is used to divide the grid into Sweep, because the grid is divided into cuboid and mesh, which is easy to calculate. Taking into account the working state of the anchor bolt, the analysis of the allowable drawing load of the bolt is also taken by the method of contact analysis. Firstly, the contact pair is defined. Because the flexible work pressure injection through bolt, injection pressure, rod radial expansion to the direction of extrusion of rock, rock bolt, so the wall and the anchor hole wall extrusion contact, therefore, set the anchor wall and anchor hole wall of contact. Because of the anchor rod body compression expansion, active extrusion wall, so the selected anchor whole wall for the target surface, the outer wall of the bolt body as the contact surface (Meng et al., 2015). Considering the anchor wall as the polymer material, the anchor whole wall is uneven, so the friction coefficient of anchor wall and anchor whole wall can select a larger value. The anchor whole surface is defined as the target surface, and the outer surface of the anchor bolt is the contact surface, and the outer surface of the outer surface of the outer surface of the bolt is the external normal of the surface element. The external normal of the target surface points to the contact surface, and the normal surface of the contact surface points to the target surface. At the same time, it gives a certain amount of displacement of the left end of the rod, and carries out second load steps. By changing the amount of displacement, the steel wire and the polymer material can meet the allowable stress. At the same time, the original 1/4 model is extended to the whole bolt body and surrounding rock mass model and the constraint force acting on the right end face of the anchor bolt is taken as the allowable drawing load of the flexible compression anchor bolt. When the elastic modulus is less than 90MPa, the Poisson ratio of polymer materials, the allowable anchor pull-out load increases, and when the elastic modulus is greater than 90MPa, small material Poisson's ratio but can get large allowable pull-out load, but the growth trend slowed down. Therefore, when the elastic modulus of polymer material is greater than 90MPa, it is not ideal to improve the drawing load by changing the material properties. Besides the position of the inner wall close to the anchor bolt, the allowable drawing load increases with the increase of the distance between the center of steel wire and the inner wall. But from the numerical point of view, the increase is not large, so in the process of the anchor, the steel wire can be inclined to the outer wall, in order to increase the allowable drawing load. In the finite element analysis, the elastic modulus of the polymer materials for 70MPa, bolt diameter 13mm, diameter 26mm, elastic modulus of rock material is 800MPa, Poisson ratio is 0.32, the Poisson's ratio of 0.45 bolt material, anchor hole diameter 28mm, the bolt filling pressure is 3~ and 8MPa respectively, the stress through the comparison of the axial and radial bolt outer ring, the influence of internal pressure on flexible pressurized anchor. With the increase of internal pressure, bolt allowable pull-out load change increases, but looked from the value increase is not obvious, while the anchor ring increase of stress and radial stress with internal pressure increases, the pressure increases, the force of bolt is worse, but the strong performance of anchorage. With the increase of the diameter of steel wire, the drawing load of anchor bolt increases, and is almost linear. And when the diameter is small equal to 2.5mm, the deviation is small, but when the diameter is

greater than 3mm, the deviation increases, that is, the proportion of the two are different.

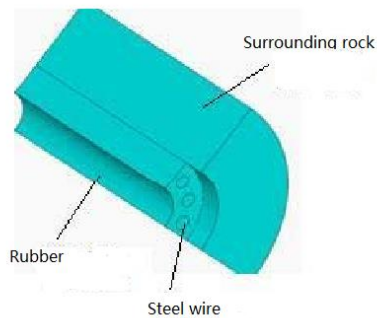

Figure 6: Schematic diagram of the system login interface.

4. Conclusion

In this paper, the history of the development of anchor and its theory are summarized and analysed. On this basis, a new type of bolt and anchor member is studied. By destroying the summary on force of bolt, the classification of the anchoring force and the bolt anchoring force mathematical model of various components. At the same time, through the experiment, discuss the internal pressure of anchor bolt component allowable pull-out load and shear capacity influence, according to the work characteristics of bolt, finite element model is established, and the model of contact analysis, discuss the design parameters of bolt anchoring system and bolt allowable pull-out load effect, and compared the results with the mathematical model, test, mutual authentication. Based on the mechanics model, gives the anchor stress field, including wire tensile stress calculation formula of longitudinal bolt body polymer material stress, radial stress, circumferential stress and shearing wire between the polymer and the stress calculation formula. This is a new type of anchor bolt anchor component calculation, structure design, size parameter selection, the anchoring effect and failure analysis provides a theoretical basis for it.

Acknowledgments

The authors acknowledge the 2016 Study Subject on the Education and Teaching of Young Teachers in Shandong Province, Subject name: Study on Physics Inquiry-based Teaching Design and Practice in Higher Vocational Colleges, Subject number: 16SDJ086.

Reference

- Chou W., Zhao F., 2015, The rigid flexible coupling dynamics of arm drilling anchor machine analysis of, *Coal technology*, 34(5), 262-265, DOI: 10.13301/j.cnki.ct.2015.05.101.
- Gao D., Li Y., 2016, Experimental study on mechanical properties of tensile anchor bolt, *Yangtze River*, 4, 58-62.
- Gong B., Lin R., Xu H., 2016, Study on the air supply pressure regulating device for the performance test of coal mine anchor rod, *Coal mine machinery*, 12, 96-98. DOI: 10.13436/j.mkjx.201612035
- Kan L., Qian Y., 2016, Coal mine bolt and component mechanical properties test study of, *Coal science and technology*, 2, 88-90. DOI: 10.3969/j.issn.1008-3731.2016.02.034
- Kang H., Lin J., Wu Y., 2015, Mechanical properties of bolt and matching. *Journal of China coal society*, 40(1), 11-23.
- Li Z., Wang L., Lu Y., 2015, High strength bolt mechanical properties and structural optimization of *Mine safety*, 46, 11, 54-57.
- Luo X., Xie X., Kuang A., 2015, Experimental study on durability of FRP anchors. *Journal of Railway Science and engineering under corrosive environment*, 6, 1341-1347.
- Meng X., Kang H., Lin J., 2015, Bolting. *Coal mine safety, thrust ball bearing, friction reducing mode based on* 46, 10, 60-63, DOI: 10.13347/j.cnki.mkaq.2015.10.017.
- Su Z., 2016, Chemical analysis of the mechanical properties of aluminum magnesium alloy badminton racket under heat treatment, *Chemical Engineering Transactions*, 55, 247-252, DOI: 10.3303/CET1655042.
- Wang F., 2016, Experimental study on the matching of the pre-tightening force of the combined support with strong anchor bolt. *Zhongzhou coal*, 7, 61-66, DOI: 10.19389/j.cnki.1003-0506.2016.07.014.