

Process Simulation and Costing Study for the FT-Liquid Fuels Production from Steam Glycerol Reforming

Piyapong Hunpinyo^{a,c*}, Phavanee Narataruksa^{b,c}

^aDivision of Chemical and Process Engineering Technology (CPet), Faculty of Engineering and Technology, King Mongkut's University of Technology North Bangkok (Rayong Campus)

^bDepartment of Chemical Engineering, Faculty of Engineering, King Mongkut's University of Technology North Bangkok (KMUTNB)

^cResearch and Development Center for Chemical Engineering Unit Operation and Catalyst Design (RCC), STRI Building, Floor 1st and 7th (Room 702), King Mongkut's University of Technology North Bangkok (KMUTNB)
 piyapong.h@eat.kmutnb.ac.th

There are various outlets for disposal and utilization of the crude glycerol generated in biodiesel plants in Thailand. For large scale biodiesel manufacturers, crude glycerol can be refined into a pure form and then be used in food, pharmaceutical, or cosmetics industries. For small scale manufacturers, however, purification is too expensive to be performed in their manufacturing sites. Their crude glycerol is usually sold to large refineries for upgrading. In recent years, however, with the rapid expansion of biodiesel industry, the market is being flooded with excessive crude glycerol. As a result, biodiesel manufacturers only receive 0.07 - 0.1 US\$/kg for this glycerol. Therefore, manufacturers must seek new, value-added uses for this glycerol.

In order to convert crude glycerol into valued-added products through thermo-chemical methods with an alternative for utilizing this waste stream. This paper focuses on the conceptual design for the production of a promising biofuel source out of waste glycerol to be integrated within a small stand-alone biodiesel plant in the south of Thailand. The biodiesel production plant used in the process model, is supposed to give about 46,000 tons of crude palm oil per year. To produce this amount 14,735 kg/d raw glycerol material is needed. The simulation program proposes a detailed superstructure embedding the alternative technologies involved. The commercial simulators ASPEN Plus is used to construct the process modelling, simulations and economic potential are performed to investigate different conditions for an integrated plant. Briefly, glycerol as a waste product from the trans-esterification of small plant oils and animal fats is first reformed using steam reforming. By concept, the syngas obtained is cleaned up and its composition is adjusted in terms of the ratio H₂/CO and then fed to the Fischer-Tropsch (FT) reactor. The novelty of this process lies in the use of a Ruthenium-based catalyst for the conversion of syngas to synthetic fuels. RYield model based on experimental data is used for formulating the product distribution of hydrocarbons (C₅-C₂₀) as stated by Anderson-Schulz-Flory (ASF). The synthetic fuel production is to be approximately 2,692 L/d in which overall conversion per pass equals to 35%. The production of FTs liquid is separated while the off-gas as by-product is using for cogeneration with gas engine system to produce the electricity.

For providing good asset out of the glycerol based on current market prices, the analysis reveals that the production is economically feasible, with a production cost for the hydrogen of \$4.71/kg, but still struggling to survive in business for reaching adequate profit. Meanwhile, the results from the FT process simulations, along with an economic evaluation, appear to be a very promising technology for synthetic fuel production, but the cost structure for benefit makeup is still under study. Noticeably, the integrated process simulation is as effective as possible and both the secondary steam from pre-treatment and steam drying would be used in the reforming and FTs plant, to knock down the production cost.

1. Introduction

Due to the environmental and global warming concerns, world consumption of captive and merchant hydrogen is projected to greatly increase in the future, especially in developing countries in Asia. One of the workarounds to this hot issue is to apply biomass based raw materials to produce hydrogen fuel. Glycerol ($C_3H_8O_3$) is the main by-product of biodiesel transesterification process from vegetable oils or animal fats. In general, about 1 kg crude glycerol is produced for every 10 kg of biodiesel (Dou et al., 2009). As a by-product of the biodiesel industry the crude glycerol (80 - 88 % pure) contains methanol, water, and some valuable salts (soaps) (Ahmed, 2010). Obviously, the presence of three last impurities needs to be disposed as a hazardous waste, which the majority is a costly process and the low market price of crude glycerol makes it uneconomic (Zhang et al., 2003). An alternative solution could be operated in the economizing mode without treatment options, namely, hydrogen production is a promising choice to manage the large excess of crude glycerol because the impurities content in crude glycerol always include methanol and water, both being reactants in the reforming process (Valliyappan et al., 2008). Moreover, the next great by-product that can help biodiesel plants to stay profitable even with price swings in hydrogen and limited growth potential.

As previous report, Ahmed and Papadias (Ahmed, 2010) evaluated the economic feasibility of distributed hydrogen production from glycerol derived as a by-product of the biodiesel industry. However, these technological descriptions have been limited public-domain knowledge of the heuristics involved during method for systematic process analysis. Therefore, this study provides nearly the same capacity of glycerol clearer details on the process engineering simulation as well as deeper technical and economic data for the coupling of glycerol reforming to syngas mixtures. The most elegant way for the recovery of pure hydrogen from the hydrogen-rich syngas is the pressure swing adsorption (PSA).

Here, the framework is categorized in three sections as follows: Section 1 proposes a brief conceptual (ideally) design of the process configurations and simulations. Section 2 shows the economic evaluation results, including a financial analysis. Especially, the economic viability of this pathway is determined by the availability and cost of crude glycerol, and the cost of producing hydrogen from it. Finally, A concept of integration for FTs simulation configuration is shown partly.

2. Scope and methodology

The feasibility project reviewed the availability of crude glycerol which is used to calculate the amount of hydrogen fuel that can be produced annually in Thailand. The case study deals with a feedstock of crude glycerol in a capacity of 14,735 kg/d which is proposed according to a small scale of the stand-alone biodiesel plant. The flowsheet synthesis is carried out using process simulation software as tools. This procedure is to generate the material and energy balances from which the requirements for feedstock, consumables, utilities and energy needs are calculated by an academic package ASPEN Plus v8.8 (licensed by KMUTNB). Cost analysis is done by first estimating capital and operating costs. Accordingly cost of production unit of hydrogen fuel is calculated for 20-y plant lifetime, with a discounted cash flow analysis.

3. Result and discussion

3.1 Process simulation

The process flow diagram of generation of hydrogen from glycerol is given in Figure 1. The main parts of the process configuration can be broken into two major steps, including: steam reforming of crude glycerol to syngas according to the reaction ($C_3H_8O_3 + 3H_2O \rightarrow 3CO_2 + 7H_2$), and hydrogen purification. Initially, the reforming reaction is strongly endothermic and requires a combination of catalysts, excess steam, and temperatures greater than 600°C to achieve high conversions of crude glycerol to hydrogen and carbon oxides. The actual reaction mechanism is quite complex, which may be overviewed as a combination of both crude glycerol decomposition ($C_3H_8O_3 \rightarrow 3CO + 4H_2$), and water-gas-shift (WGS) reaction ($3CO + 3H_2O \leftrightarrow 3CO_2 + 3H_2$). Briefly, the equilibrium compositions of syngas mixtures obtained from the reformer are determined by solving the minimization problem of the Gibbs free energy. The steam reformer is simulated as RGIBBS adiabatic reactors, which it is operated with a molar steam-to-carbon ratio (S/C) of approximately 3. The gas composition stream leaving the reformer (reformate at chemical equilibrium at 800 °C) is cooled and then processed in a high-temperature WGS reactor at 400 °C by RSTOIC reactor. The reformate gas composition is sent to the PSA unit. The undesired gas containing the carbon oxides and methane, along with the un-recovered hydrogen is returned to a combustion unit with oxygen to recover heat for the reforming process. Additional natural gas is optionally fed in the combustor, if necessary.

3.2 Material and energy balances

Mass and energy balance from process simulation is presented in Table 1. The input structures to the process simulation are crude glycerol, steam, oxygen and natural gas while the output structure is a hydrogen-rich gas reformat with a specific composition, including 72 % of H_2 , 23 % of CO_2 , 2.5 % of CO , 2.3 % of CH_4 , 1.1 % of H_2O and Other hydrocarbon. The purity hydrogen component is extracted conceptually with 80 % recovery at 20 atm. In order to estimate the energy conversion efficiency to hydrogen production, the base-case can be converted glycerol to hydrogen with an efficiency of 65.47 % which is slightly lower than reported in previous study (Ahmed, 2010). As seen in Eq(1), energy efficiency is expressed as lower heating value (LHV) for the total energy out of the hydrogen exiting the PSA unit divided by the total of energy inputs into the domestic process, i.e., Σ (raw material in unit of MJ/kg + natural gas in unit of MJ/kg + electricity in unit of MJ). The reaction yield of a kmole of H_2 can be formulated per 7 times of kmol of glycerol, with the resulting yield being 77.28 % as followed in Eq(2). Energy losses from the transmission of electricity did not include.

$$n_{eff} (\%) = \frac{H_{2,LHV}}{Glycerol_{LHV} + NG_{LHV} + Electricity} \times 100 \quad (1)$$

$$Yield(\%) = \frac{kmol/day \text{ of } H_2}{7 \times (kmol/day \text{ of } Glycerol)} \times 100 \quad (2)$$

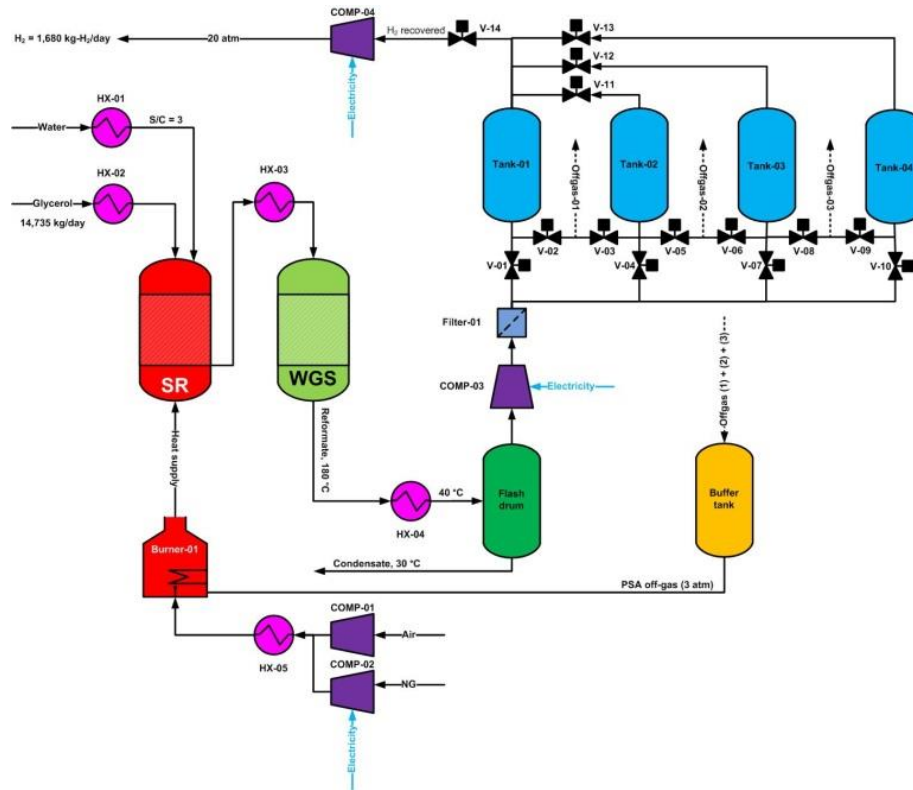

Figure 1: Schematic representation of the base-case SGR to hydrogen fuel flowsheet

3.3 Cost analysis

The total direct cost includes cost of equipment, installation, instrumentation, piping and service facilities. All of them are calculated using estimates from several literature sources. The indirect costs of engineering and construction expenses and contingency are calculated by multiplying the investment with a factor that depends on rate of return and plant life. The other variable costs for cash flow include the cost of glycerol is taken into account for the lowest possible price (0.07 US\$/kg) because of by-product from the domestic biodiesel plant. Chemical engineering's plant cost index (CEPCI) is used to bring the unit costs to Q4 2013 (567.3). The fixed capital investment (FCI) is calculated as sum of total direct cost plus the indirect cost. The cost parameters used in calculation are also given in Table 1.

As shown in Figure 2, the forecast cumulative net cash flow over the life of a base-case project using the above nominal values is positive. The profitability of the domestic plant depends primarily on the cost of crude glycerol, which is the sole raw material, and the cost of hydrogen, which directly determines the cost of the major product of the process. With the H₂ production rate of 1,680 kg-H₂/d, the FCI is calculated to be \$2.23 million, and the total capital investment (TCI) is thus \$ 2.47 million, respectively. The economic status can be determined by return on investment (ROI), discounted payback period (DPBP), and discounted cash flow return (DCFR) for identifying economic situation. Initially, the average ROI is calculated to be $(\text{Annual net profit}/(20\text{-year plant life} \times \text{TCI})) \times 100 \% = (1.8/(20 \times 2.47)) = 3.64 \%/\text{y}$, while DPBP equals to 7 years accounts for being positive discounted cash flow curve. Most interestingly, the break-even (minimum) price of hydrogen is \$ 4.71/kg-H₂, which is again lower than the aforementioned price (\$ 4.86/kg-H₂). However, this price might be reduced further to 5 - 10 % when increases process efficiency and lower operational costs. The results indicating that the integrated glycerol steam reforming process can be economically attractive even with relatively low glycerol prices. Thus, it may be concluded that the proposed process has the economic potential that justifies further development.

Table 1: Overall mass and energy balances (fourth) and costs of materials and utilities (third), and then cost breakdown of plant, including cost items and cost parameters (first and second)

1. Descriptive parameters	Value
Basis year for analysis	2013
Analysis plant lifetime	20 years
Construction period	2 years
- 1 st year	75%
- 2 nd year	25%
Start-up time	12 months
Salvage value	Neglected
Number of operators	10 persons

2. Cost items	million \$
1. Total direct costs	1.663
2. Total indirect costs	0.665
3. Fixed capital investment (1+2)	2.228
4. Working capital investment	0.411
5. Total capital investment (3+4)	2.470

3. Items	Value	Unit
Glycerol	0.07	\$/kg
Natural gas	3.88	\$/GJ
Electricity	0.064	\$/kWh
Air compression	0.9	\$/100 m ³
Water	0.53	\$/m ³
Waste water	0.2	\$/m ³ [5]

4. M&E balances	Mass (kmol/day)	Energy (MW)
Inputs		
Glycerol	154	2.73
Natural gas	-	0.78
Electricity	-	0.06
Output		
Hydrogen	883	2.34

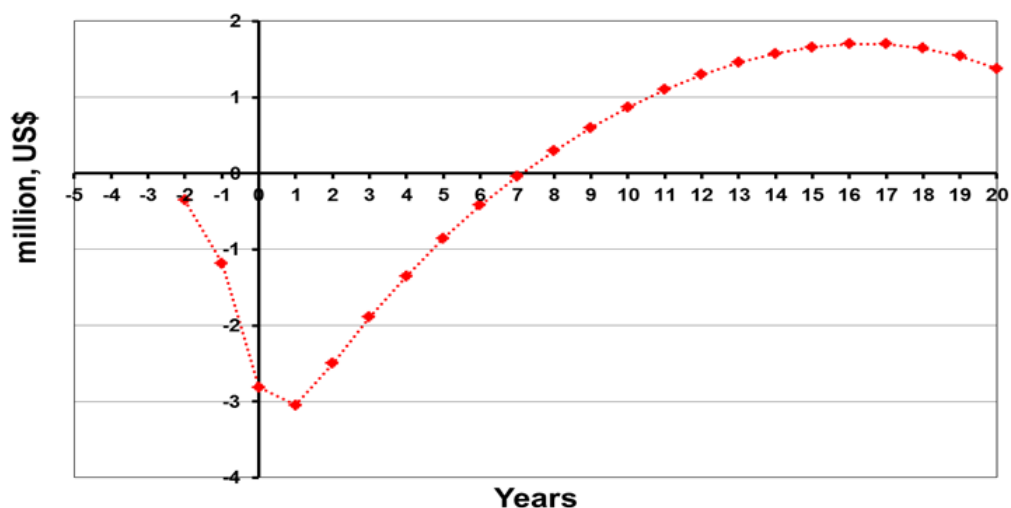

Figure 2: The forecast cumulative net cash flow over the life (20 y) for a base-case of steam glycerol reforming project

4. Conceptual integration of FTs configuration

The proposed concept of integration for FTs configuration is depicted in Figure 3. The syngas obtained from glycerol reforming is formulated conceptually to FTs process to estimate the amount of liquid productivity. RYield model based on experimental data is used for formulating the product distribution of hydrocarbons (C5-C20) as stated by Anderson-Schulz-Flory (ASF). The synthetic fuel production is to be approximately 2,692 L/d in which overall conversion per pass equals to 35 %. However, the cost analysis is still under study because of the complexity of FTs process, the heat integration between hot and cold process streams should be validated exactly to makeup both thermal efficiency and benefit.

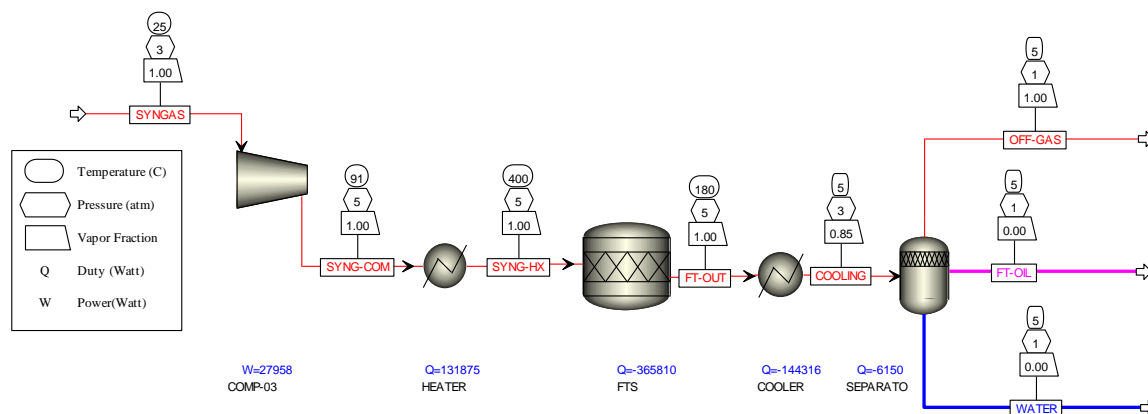

Figure 3: Process simulation of Fischer-Tropsch synthesis (FTs)

5. Conclusions

A base case study has been developed to assess a hydrogen production plant using 14,735 kg/day of crude glycerol to produce 1,680 kg-H₂/d of product. With a reduction in the costs of glycerol and operating cost (natural gas) or the increase in the selling prices of the hydrogen fuel, the process can make higher profit. The break-even (minimum) price of hydrogen is \$ 4.71//kg-H₂, which is again lower than the aforementioned price (\$4.86 /kg-H₂). A break-even point analysis indicates that the forecast cumulative net cash flow over a 20-y plant life of a project is positive. Moreover, the average ROI is 3.64 %/y and DPBP is to be 7 y, respectively. The proposed concept of integration for FTs configuration is basically simulated to estimate the amount of liquid productivity. The synthetic fuel production is to be approximately 2,692 L/d in which overall conversion per pass equals to 35 %. However, the cost analysis is still under study because of the complexity of FTs

process, the heat integration between hot and cold process streams should be validated exactly to makeup both thermal efficiency and benefit.

Acknowledgments

This research funding was granted by King Mongkut's University of Technology North Bangkok (KMUTNB) under contract No. KMUTNB-NEW-58-15 and the authors would like to thank the Research and Development Center for Chemical Engineering Unit Operation and Catalyst Design (RCC) for providing all facilities.

References

- Ahmed S., 2010, Hydrogen from Glycerol: A Feasibility Study. DOE Hydrogen Program.
- Dou B., Dupont V., Williams P., Chen H., Ding Y., 2009, Thermogravimetric kinetics of crude glycerol. *Bioresour Technol.*, 100, 2613 - 2620.
- Valliyappan T., Ferdous D., Bakhshi N.N., Dalai A.K., 2008, Production of hydrogen and syngas via steam gasification of glycerol in a fixed-bed reactor. *Topics in Catalysis.*, 49, 59-67
- Zhang Y., Dubé M.A., McLean D.D., Kates M., 2003, Biodiesel production from waste cooking oil: 2. Economic assessment and sensitivity analysis. *Bioresour Technol.*, 90, 229-40.