

Design of a Knowledge-Enabled Supervisory Framework for the Detection of Abnormal Conditions at Process Pilot Plants

Chrysovalantou Ziogou^{a,*}, Stelios Krinidis^b, Dimosthenis Ioannidis^b, Dimitrios Tzouvaras^b, Simira Papadopoulou^c, Spyros Voutetakis^a

^aChemical Process and Energy Resources Institute (CPERI), Centre for Research and Technology Hellas (CERTH), 6th km Harilaou-Thermi rd, POBOX 60361, Thessaloniki, 57001, Greece

^bInformation Technologies Institute (ITI), Centre for Research and Technology Hellas (CERTH), 6th km Harilaou-Thermi rd, POBOX 60361, Thessaloniki, 57001, Greece

^cDepartment of Automation Engineering, Alexander Technological Educational Institute of Thessaloniki, PO Box 141, Thessaloniki, 54700, Greece
 cziogou@cperi.certh.gr

This work presents a knowledge-enabled supervisory monitoring (KSM) framework which is used for the enhanced operational analysis of processes that are controlled by industrial automation systems. The objective of the knowledge-enabled platform is to provide notifications to the operators about potential abnormal behaviour of the underlying control equipment or subsystem. A set of rules designate the predefined conditions that are considered nominal which are described by a Finite State Machine. The systems is represented by an ontology integrated into a Common Information Data Exchange Model (CIDEM) using existing standards (ISA-95, implemented by a B2MML (Business To Manufacturing Markup Language) XML schema) for the information modelling while the decisions are provided in an informative manner to the operator. The functionalities of the KSM and its potential are exemplified to a continuous process at CERTH which is monitored by a Supervisory Control and Data Acquisition System (SCADA).

1. Introduction

The increase of process complexity in conjunction with the increase of the data produced by the process operations make the use of enhanced methods for information extraction more imperative than ever before. Therefore, the timely processing and the accurate notification about the status of the involved sensors, devices, equipment, or systems is necessary to maintain product quality, prevent undesired effects and avoid incidents related to the measured variables of the process (Natarajan, 2012). A precise and early notification mechanism of potential abnormalities is essential to be developed beyond the typical alarm notification systems that are already in place for the safety of the process and the involved operators. On the other hand the increasing level of automation can provide useful information and valuable knowledge since large amounts of online data are available to be evaluated upon demand (Harjunkoski, 2015).

The operation of process systems takes place at a highly dynamic environment. The integration of data and information derived from complex and highly dynamic processes is of major importance to improve both timely decision making and the improvement of process operation and quality of final products. In order to gain the most out of the existing data and the structured information, the integration between Operation Technology (OT) and Information Technology (IT) is necessary. The interoperability between OT and IT systems is a critical concern during the design and development of a knowledge-enabled platform. Currently data are analysed using conventional tools (Muñoz, 2012) whereas the decision-making is partially performed at a later stage using respective tools by the plant operators and the process managers. Therefore, the motivation of this work is mainly the development of a knowledge-based supervisory monitoring (KSM) framework that will enable the online notification of the status and condition of the involved system using process data combined with an ontology-enabled process representation.

1.1 Importance of Fault Identification at Process Systems

During the operation of a process the monitoring and the appropriate visualization of the alarms, notifications or performance data and their evaluation is becoming a challenging issue for the operators. Furthermore, in case of multiple simultaneous alarms highly skilled operators are necessary to identify the priority and the reasons that caused them. A subset from the alarms that appear during the operation are related to faults, e.g. degraded performance of a filter that leads to high resistivity of water, whereas others are related to the dynamics of the process, e.g. highly exothermic reactions can lead to increase of furnace temperature. In this work the focus is towards the alarms that might hinder an abnormal behaviour related to a device or equipment of the process. A fault can be defined as an undesired deviation of at least one property or parameter of the system from the normal condition, e.g., a pump malfunction of a feed system. Also the unexpected variations that affect the performance of a system is considered as a fault (Zhang, 2008) that denotes a malfunction. In case the fault affects the ability of the system or process to operate (interruption of the process functions) under desired operating conditions and defined set-points then it is considered a failure. In general the alarms built into the automation systems use single variable monitoring methods that do not provide information about the underlying conditions or factors that caused the alarms to the operators besides the variable (tag) that exceeded the predefined limits. Overall faults can lead to system failures it is important to identify potential abnormal situations even with a slight uncertainty margin and notify the operator to act accordingly. Thus, there is a need for effective mechanisms and tools for active fault detection that could coexist with the existing industrial automation systems infrastructure and to convey notification information to the operator in a seamless manner through the Human Machine Interface (HMI) of the process.

2. Knowledge-based representation

In the dynamic environment of a process most of the states (measurements such as temperatures, pressures, flows etc.) of the physical systems evolve continuously. Therefore, the identification of the normal or abnormal status needs to be implemented in the time frame determined by the process operation. In this work, the identification procedure is enhanced by a knowledge-enabled system that relies on an ontological approach realized by a Common Information Data Exchange model (CIDEM). A knowledge-based representation of a process system can support the explicit description of the knowledge in a specific domain and exploits it through appropriate reasoning mechanisms in order to provide high-level problem solving performance (Farannini et al., 2011) or in our case the potential fault identification.

The knowledge which is integrated at the CIDEM is used by the reasoning mechanisms to result to an abnormal notification system for potential faults and suggestions for alarm prioritization. The ability of ontologies to represent correlations under boundaries and constraints between different subsystems is exploited to document the process equipment dependencies. These correlations and dependencies are afterwards invoked by a set of rules that is able to check if the status is within the nominal state. Otherwise any deviation from the nominal case is a potential fault which is accordingly reported to the process operator. The objective is to visualize the data in a simplified non-disruptive manner to the traditional HMIs of the automation system.

2.1 Common Information Data Exchange Model (CIDEM)

A CIDEM defines the high level domain model comprising the basic elements (events, relations, interfaces etc.) of the underlying process system. The CIDEM specification consists of architecture and concepts of CIM, and the language (by which the CIDEM schema is defined). The scope is to provide information and semantic model for the domain objects of the process system. The description of these objects is related to static data and dynamic data. The static data (e.g. data about equipment characteristics etc.) will be used for the interpretation of the dynamic data (e.g. the measurements from the sensors). The CIDEM process the requests from the framework components and store data in a hybrid repository. The plant ontology is the knowledge representation of the plant structure, the hierarchical equipment structure and the equipment interconnections (Venkatasubramanian, 2006). Based on that the CIDEM has been developed, aiming to provide a model of information elements (e.g. concepts, events, relations, and interfaces) used for information exchange. The main elements of the CIDEM ontology are shown in Figure 1.

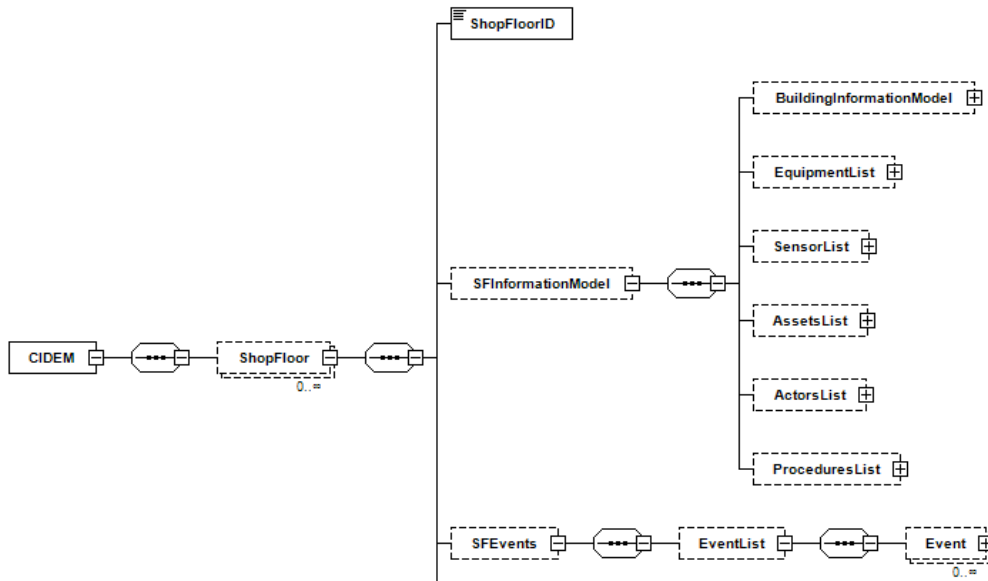

Figure 1: Developed Ontology for the Representation of Process Systems

The CIDEM definition is considered as a shared vocabulary which is used to address the information needs of the plant-floor components. More specifically CIDEM defines how managed elements are represented as a common set of objects along with the relationships between them (DSP0201,2009). Standards such as B2MML (Business To Manufacturing Markup Language), which is an ISA-95 XML implementation has been utilized (ANSI/ISA-95.00.03-2005). The CIDEM specification consists of architecture and concepts, language (by which the CIDEM schema is defined), and a method for mapping CIDEM to other information models. The CIDEM used in this approach has been defined using well-known industrial standards, so as to be reusable and compatible with external systems. The architecture is object-oriented, while its elements are represented as classes, whereas the relationships are represented as associations.

The CIDEM models both static (SFInformationModel) and dynamic data (SFEvents) of the plant-floor. Based on this ontology, CIDEM is able to receive and store, the dynamic information of the plant-floor which is the events, divided into two main categories, the measurements and the alerts. Each event is characterized by an unique identification number, its type (measurements or alert), the timestamp that it is occurred, the space (location), the source that produce it and other information describing in more details the event according to ISA-95. An indicative example of the XSD schema describing the alerts in the CIDEM is shown in Figure 2.

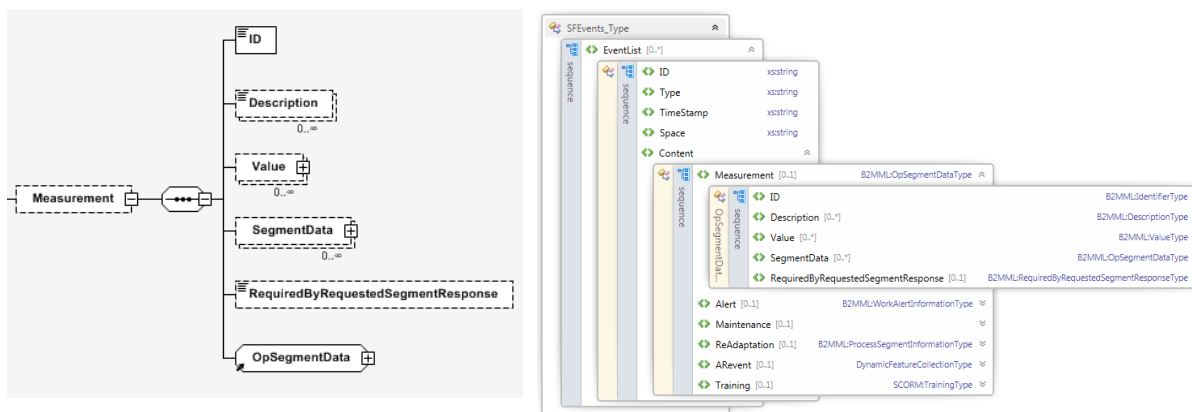

Figure 2: Measurement schema and properties

On the other hand, the static information of the plant-floor, is comprised of the plant-floor geometry, the equipment (ID, description, type, etc.), the sensors (ID, description, type, location, etc.) that are used for monitoring the devices/equipment, as well as the assets, the actors and the procedures that describes the

operations in the plant-floor environment. Furthermore, the CIDEM is specified by the inputs/outputs interfaces between the interconnected components and the data repository.

2.2 Detection and Notification of Abnormalities using Behaviour Rules

As the CIDEM defines the high level domain model comprising of the basic elements (events, assets, relations, interfaces etc.) there is a second level of analysis that uses the stored data. In order to provide notification of potential abnormal conditions, the developed methodology needs to be deployed online and respond in close to real-time by accessing information from the CIDEM. For this reason the static data support the evaluation of the dynamic data (events, alerts etc.) at each sampling interval which is determined according to the dynamics of the involved equipment. A Finite State Machine (FSM) formulation is used to describe the procedure during which information or tasks move from one state to another, according to a set of rules (Ziogou, 2013). A FSM M is defined by a tuple $(Q, q_0, \delta, \lambda, X, Y)$ in which Q is a finite set of states, $q_0 \in Q$ is the initial state, δ is the state transfer function, λ is the output function, X is the finite input alphabet; and Y the finite output alphabet. The FSM represents all feasible states of the components and the logical rules that trigger the transitions between the states. FSMs can be fully semi-automatic or completely automatic, depending on the involvement of the process operator or not. The scope of the invoked rules is to extract adequate information to notify the operator about the performance of the involved subsystem of the plant. The transition rules are represented via a propositional-based logic approach using a combination of logical operations (*AND*: \wedge , *OR*: \vee , *NOT*: $!$) and a set of Boolean variables (β), which are related to the status of each equipment of the process. Thus, the complete set of rules is derived by the operation of the unit's subsystems and their constraints. Each rule is associated with a transition at the FSM. Overall the FSM describes the evolution in time of a set of discrete and continuous state variables.

In the case of identification of abnormal conditions the transition rule provides simple reasoning of process data. The FSM is used to model the generic behaviour of the equipment and not only the identification of the abnormal conditions. In case a rule invokes a transition to the state that designates the degradations or fault of the equipment then the output triggers the notification mechanism. Otherwise the FSM can produce informational output to be used in conjunction with the monitoring information from the I/O field.

3. Knowledge-enabled Supervisory Monitoring (KSM) Framework for Process Monitoring

The objective of a Knowledge-enabled Supervisory Monitoring (KSM) framework is to provide useful information and notification to the operators besides the typical measurements available at the existing HMIs. The traditional process plants rely on automation architectures (such as Supervisory Control and Data Acquisition – SCADA) that monitor and control the subsystems by real-time measurements from the I/O field. The analysis of the operation and the performance evaluation are conducted at a secondary stage using data that are stored at Process Information Management Systems (PIMS). On the other hand, the integrated KSM framework is based on the requirements and specifications of a continuous process plant. Initially the structure of the process plant and of the automation system is derived using engineering schematics and process equipment details that are subsequently stored according to the CIDEM structure to the data repository. Furthermore, a connection between the equipment and the related operations (work schedules) is created. In that context the KSM framework consists of the Rules of operation, the CIDEM and the ontology. Also appropriate middleware for the data exchange is developed and deployed that is based on industrial-grade standards. Figure 3 shows the architecture of the KSM framework and the connection to the process unit.

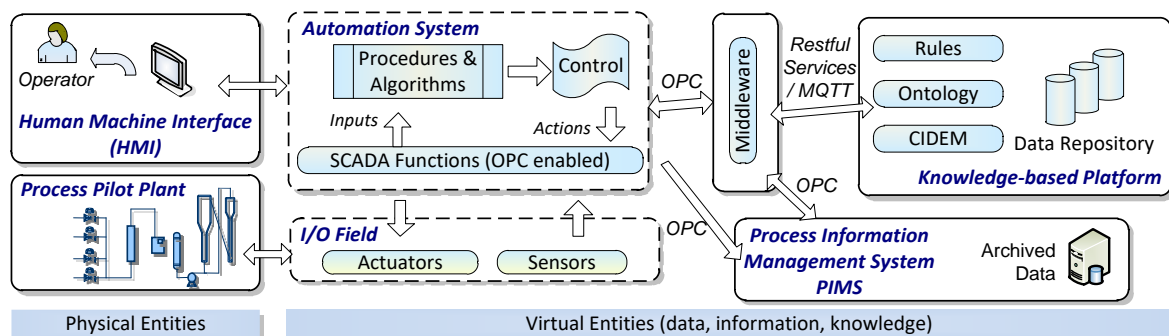

Figure 3: Components of the KSM platform and information flow

The KSM framework analyses the functions performed by the automation system of the process and also defines other functions typically associated with the process operations. The main supported areas are the data collection, the performance analysis, the events/alarms tracking and the procedures definition. Overall the scope of the framework is to demonstrate that the instantiated platform can provide interfaces allowing the connection of all of the automation system to the smart knowledge-aware functions (such as the supervisory control, physical process equipment, and operation rules/conditions) and to define the formalism that supports heterogeneous information to be integrated and evaluated based on predefined methods.

4. CERTH/CPERI's Use Case – Continuous Process Plant

The demonstration of the developed platform is instantiated for the auxiliaries of a pilot plant which is designed and operated at the premises of CERTH/CPERI. The pilot plant is fully automated and intuitive HMIs are available to the operators. The automation system relies on a supervisory control and data acquisition (SCADA) architecture. The subsystem is responsible for the water purification of a fuel production system of a continuous process. Figure 5 shows an indicative interface which is used for the monitoring of the status of the equipment of the water purification subsystem. All system components (pumps, valves, etc) are controlled by on/off commands, control algorithms (e.g. PID controllers) or by pre-programmed procedures. The monitoring system provides real-time information regarding the state of the plant, as well as, trending features related to the evolution of the experiments. Figure 4 shows an indicative interface which is used for the monitoring.

The knowledge-enabled platform provides information related to early warnings of undesired behaviour or response of the equipment into consideration. An indicative case is the evolution of the conductivity profile by observing the measurements of conductivity and resistivity along with the time that the circulation pump operates. In case of a significant time deviation without respective alteration in the conductivity then a potential malfunction of the pump is present or the electrical components related to the electric circuit.

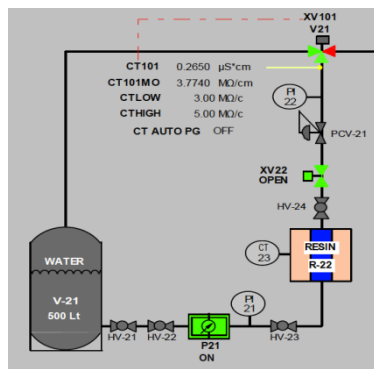

Figure 4: HMI of the Subsystem

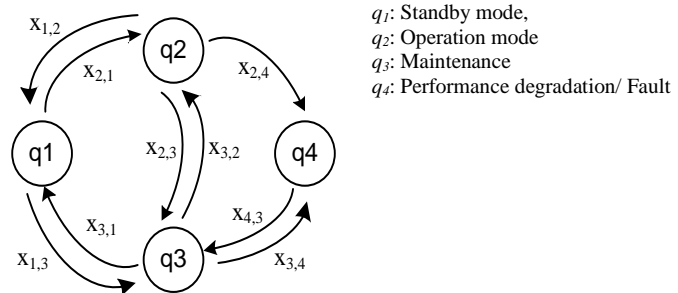

Figure 5: FSM for the Water Purification Subsystem

As stated earlier the CIDEM represents both static (e.g. data related to the nominal water conductivity ranges) and dynamic data (e.g. the status of the pump) of the pilot plant combined with information from the Process and Instrumentation Diagram (P&ID) of the plant. The KSM platform provides notification based on a set of predefined rules which are modeled by the FSM structure. Figure 5 shows an indicative example for the behavior analysis of the components related to the water purification subsystem, which are a two way valve, a three way valve, a pump and a conductivity meter. The states (q_1, \dots, q_4) describe the possible conditions of a water purification subsystem (standby, operation, maintenance, and fault). The notification to the user is performed only when state q_4 is reached. The transition between the states is performed according to a set of rules that define the input alphabet (X) of the FSM.

$$x_{2,4} : ((\beta_{WT} \vee \beta_{\Delta,CT21}) \wedge \beta_{P21}) \vee \beta_{P21,tmax} \quad (1)$$

Eq(1) represents the rule for the transition to the notification state ($x_{2,4}$). More specifically β_{WT} is the status of the water resistivity, $\beta_{\Delta,CT21}$ is the change of water resistivity, β_{P21} is the pump status and $\beta_{P21,tmax}$ is related to the maximum period of time that the pump operates. For example Table 1 presents the variable (β_{WT}) that monitors the water quality based on the measured resistivity of the water and the rule that activates the notification that the pump might have a malfunction (q_4). At these states the historical data of the behavior of the sensor and the actuator are evaluated at regular intervals against the real-time data. The evaluation can activate the respective transition when the value of the operation time of the pump output is beyond the expected average or if there is a significant change with an increasing slope of the output. In order for the state to change, the user response (acknowledgement of notification) is necessary for states q_3 and q_4 .

Table 1: Water Purification Subsystem - Status of the Resistivity Variable

Variable status	Description
$[\beta_{WT} = 1] \leftrightarrow [WT_{Res} \geq WT_{Res,high}]$	Variable β_{WT} is true (= 1) if and only if (iff) the water resistivity is greater/equal to $WT_{Res,high}$ (2.2M Ω)
$[\beta_{WT} = 0] \leftrightarrow [WT_{Res} < WT_{Res,low}]$	Variable β_{WT} is false (= 0) iff the water resistivity is below $WT_{Res,low}$ (2.0M Ω)

5. Conclusions

The main results of this work is the development of a knowledge-enabled supervisory monitoring framework that can identify potential abnormal conditions and notify the process operators in a non-disruptive way combining online data from the I/O field and predefined rules of operation. The use of an ontology combined with a set of rules results to an integrated solution which will be evaluated at long term by the operators. The next step will be to include more details to the representation of the ontology and utilize information from other systems already available at the shop floor related to the Computerized Maintenance Management Systems (CMMS) and the integrated Decision Support System (iDSS) where the activities related to the maintenance will be analysed to enable a comprehensive fault diagnosis and explore the potential of an early failure detection mechanisms for process systems.

Acknowledgments

The authors would like to acknowledge the financial support of European Community, project: 'SATISFACTORY - A collaborative and augmented-enabled ecosystem for increasing satisfaction and working experience in smart factory environments'.

References

- Al-Dahidi S., Di Maio F., Baraldi P., Zio E., 2015, Ensemble clustering for fault diagnosis in industrial plants, *Chemical Engineering Transactions*, 43, 1225-1230
- ANSI/ISA-95.00.03-2005, 2005, *Enterprise-Control System Integration. Part 3: Activity models of manufacturing operations management*, ResearchTriangle Park,NC: ISA
- DSP0201, 2009, *Representation of CIM using XML*, Distributed Management Task Force, Inc., Version: 2.3.1
- Ferrarini L., Allevi M., Dedè A., 2011, A methodology for fault isolation and identification in automated equipments. In: 9th IEEE Int. Conf. on Industrial Informatics, Caparica, Lisbon, Portugal, July 26-29, 157–162
- Godwin J.L., Matthews P., Watson C., 2013, Classification and detection of electrical control system faults through SCADA data analysis, *Chemical Engineering Transactions*, 33, 985-990.
- Harjunkoski I., 2015, Industrial perspectives on the deployment of scheduling solutions, *Computer Aided Chemical Engineering*, 37, 63-70
- Muñoz E., Capón-García E., Hungerbühler K., Espuña A., Puigjaner L., 2013, Decision making support based on a process engineering ontology for waste treatment plant optimization, *Chemical Engineering Transactions*, 32, 277-282
- Zhang Y., Jiang J., 2008, Bibliographical review on reconfigurable fault-tolerant control systems, *Annual Reviews Control*, 32(2), 229–252
- Ziougou C., Ipsakis D., Seferlis P., Bezergianni S., Papadopoulou S., Voutetakis S., 2013, Optimal production of renewable hydrogen based on an efficient energy management strategy, *Energy*, 55, 58-67