

# Efficiency Analysis of Advanced G Class Gas Turbine Feed with Synthetic Natural Gas (SNG) and Mixture Gas of Syngas and SNG

Po-Chuang Chen<sup>a</sup>, Hsiu-Mei Chiu<sup>a</sup>, Yau-Pin Chyou<sup>\*a</sup>

<sup>a</sup>Institute of Nuclear Energy Research, Chemistry Division, No. 1000, Wenhua Rd., Jiaan Village, Longtan Township, Taoyuan County 32546, Taiwan (R.O.C.).

ypchyou@iner.gov.tw

The system-level simulation model for Natural Gas Combined-Cycle (NGCC) plant combines advanced G class turbine with various fuels was performed in the study. The commercial chemical process simulator, Pro/II<sup>®</sup> V8.1.1, is used in the study to build the analysis model. There are three major sections which are gas turbine (GT), heat recovery steam generator (HRSG) and steam turbine (ST).

The study envisages two analyses as the basic and feasibility cases. The former is the benchmark case which is verified with the reference data of exist NGCC power plant located in Dah-Tarn, Taiwan. The Dah-Tarn NGCC power plant introduces the advanced M501G gas turbine from Mitsubishi Heavy Industries, Ltd. (MHI) and the system efficiency of the combined-cycle is 58.75 % (LHV). The latter introduces a feasibility study with advanced gas turbine and actual parameters in Taiwan. The SNG from carbonate fuel feed to M501G based combined-cycle is evaluated in the feasibility study cases first, and the mixture gas of SNG and syngas is also evaluated to compare the different of overall performance with the pure SNG case.

The results show that the system efficiency of pure SNG case is around 57 % (LHV). For the mixture gas case, the maximum ratio of syngas to SNG is 1:19, due to keep the same composition of methane is 85.9 % with the Dah-Tarn NGCC power plant. The efficiency of mixture gas case is 55.75 % (LHV).

The study shows the possibility way to use coal and reduce the CO<sub>2</sub> emission. The another advantage is the using of SNG could increases the usage of combined-cycle in Taiwan, due to the prices of natural gas is higher than coal in Taiwan and results in the higher idle capacity.

## 1. Introduction :

British Petroleum (2013) has reported that the reserves-to-production ratio for oil, natural gas and coal are 52.9, 55.7 and 109 years, respectively. Therefore, coal remains the world's most abundant fossil fuel. Taiwan is an isolated island with dense population and limited natural resources. Over 99 % of Taiwan's energy demand is dependent on import from abroad. The power generation by fuel in 2012 spreads over coal, gas, oil, nuclear, pumped hydro and renewable as 49.01 %, 26.89 %, 2.54 %, 16.14 %, 1.17 % and 4.24 %, respectively (Bureau of Energy, 2012). It means Taiwan is higher dependence on fossil fuels. There are several ways to reduce the dependence on fossil fuels, such as renewable energy, multiple fuel supply, alternative fuel, efficiency improvement of fuel utilization, etc. Conversion of solid fuel to gas fuel, liquid fuel or chemical products by adopting gasification technology is a better way to achieve the replacement of oil and natural gas by solid fuel.

In order to solve the issues of global warming and climate change, Taiwan government has inaugurated planning to reduce CO<sub>2</sub> emission and made some efforts to accomplish the target since recent years. One of the activities is increasing the amount of natural gas in electricity generation; due to the CO<sub>2</sub> emission per kW of Natural Gas Combined-Cycle (NGCC) is relatively lower than the counterpart of pulverized coal power plant. Lei and Chakib (2012) reported China's thermal electricity production. They indicated that there are several ways to increase efficiency of power and reduce carbon dioxide emissions, such as NGCC and Integrated Gasification Combined Cycle (IGCC).

Please cite this article as: Chen P.-C., Chiu H.-M., Chyou Y.-P., 2014, Efficiency analysis of advanced G class gas turbine feed with synthetic natural gas (SNG) and mixture gas of syngas and SNG, Chemical Engineering Transactions, 39, 1717-1722 DOI:10.3303/CET1439287

The storage capacity of natural gas in Taiwan is about two weeks in this moment. It means the safety issue of electricity provided needs to solve as the usage of natural gas increasing. One of the solutions is introducing gasification technology to convert carbonate fuel to synthetic natural gas (SNG). Carbonate fuel such as coal, biomass, and so on could be directly converted to SNG and delivered through exist natural gas pipeline to the power plant. The problem of storage capacity could be solved, and the partial amount of CO<sub>2</sub> from the carbonate fuel is captured in the processes of SNG conversion. If the captured CO<sub>2</sub> is tread as reutilisation and storing, the CO<sub>2</sub> emission of SNG from carbonate fuel is the same as the typical NGCC. Maria et al. (2012) simulated a model of a substitute natural gas (SNG) process based on thermal gasification of lignocellulosic biomass. They discussed three process design cases of woody biomass converting to SNG. Er-rbib and Bouallou (2013) built an ASPEN Plus process model for the syngas to methane process.

The purposes of this study are to simulate the NGCC power plant which benchmarks with the Dah-Tarn NGCC power plant in Taiwan, and compared two feed types of SNG and mixture gas of SNG and syngas.

## 2. Process description

### 2.1 Combined-Cycle System

Combined-cycle integrates the Brayton and Rankine cycles to achieve higher system efficiency, and it is consisted of three major parts which are gas turbine (GT), heat recovery steam generator (HRSG) and steam turbine (ST). The process diagram of the NGCC power plant is shown in Figure 1.

Gas turbine consists of an upstream compressor connected to downstream turbine with a spindle and a combustion chamber. Air is compressed via compressor and mixed with fuel in the combustor. The mixture gas is burned in the combustor, then goes through the turbine blades and spins the turbine to drive the compressor and generate electricity.

The M501G type gas turbine is used in the model with SNG and mixture gas of SNG with syngas feeding to simulate and analyze the system. The high-efficiency M501G gas turbine is produced from Mitsubishi Heavy Industries, Ltd (MHI). The M501G has 1,500 °C turbine inlet temperature (TIT) and 17-stage compressor that provides a near 20:1 pressure ratio. These result to provide 399MW output with 58 % (LHV) efficiency with natural gas feeding. (Mitsubishi Heavy Industries, 2013)

In general, the temperature of exhaust gas from gas turbine is higher than 500 °C. The best way is to recover the energy to generate steam, which drives the steam turbine for electricity generation. The steam is generated from heat recovery steam generator (HRSG) which consists of evaporator, superheater and economizer. HRSG is a commercial module and can be categorized by a number of ways such as the direction of exhaust gases flow or the number of pressure levels. The pressure level can be single pressure or multi-pressure.

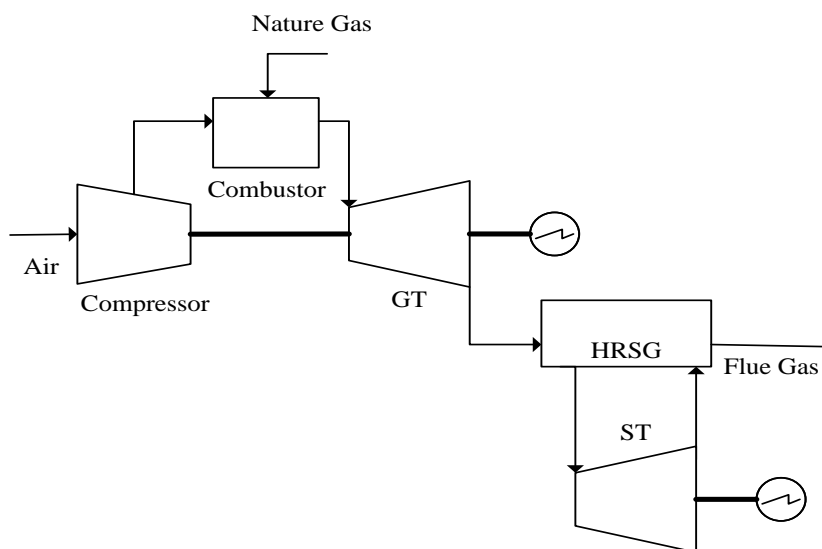

Figure 1: Process flow diagram of NGCC

Table 1: The performances of the Dah-Tarn NGCC power plant

Item	Value
Gross gas turbine output	233.9MW*2
Gross steam turbine output	256.9MW
Gross block output	724.7MW
Net plant output	708.05MW
Gross efficiency	58.75%(LHV)

## 2.2 NGCC Power Plant Located at Dah-Tarn in Taiwan

There are two stages in the Dah-Tarn NGCC power plant, stage I is based on three advanced F-Class combustion turbine and one steam turbine configuration. Stage II is based on two advanced G-Class combustion turbine and one steam turbine configuration. The study envisages the basic case which benchmarks with the stage II Dah-Tarn NGCC power plant. The temperature of exhaust gas from gas turbine is 622 °C and the temperature of flue gas is 87 °C in stage II.

GIBSIN Engineers, Ltd. in Taiwan provides that the primary fuel is natural gas (NG) with a higher heating value (HHV) of 54,207 KJ/kg and relative data. A summary of plant performance data for the NGCC power plant is presented in Table 1.

## 3. Simulation model

The system-level simulation model for NGCC power plant with various feed was performed in the study. The commercial chemical process simulator, Pro/II® V8.1.1, is used in the study to build the analysis model. Figure 2 shows the simulation processes flow diagram of NGCC power plant. Table 2 shows the compositions of nature gas from Dah-Tarn NGCC power plant in Taiwan.

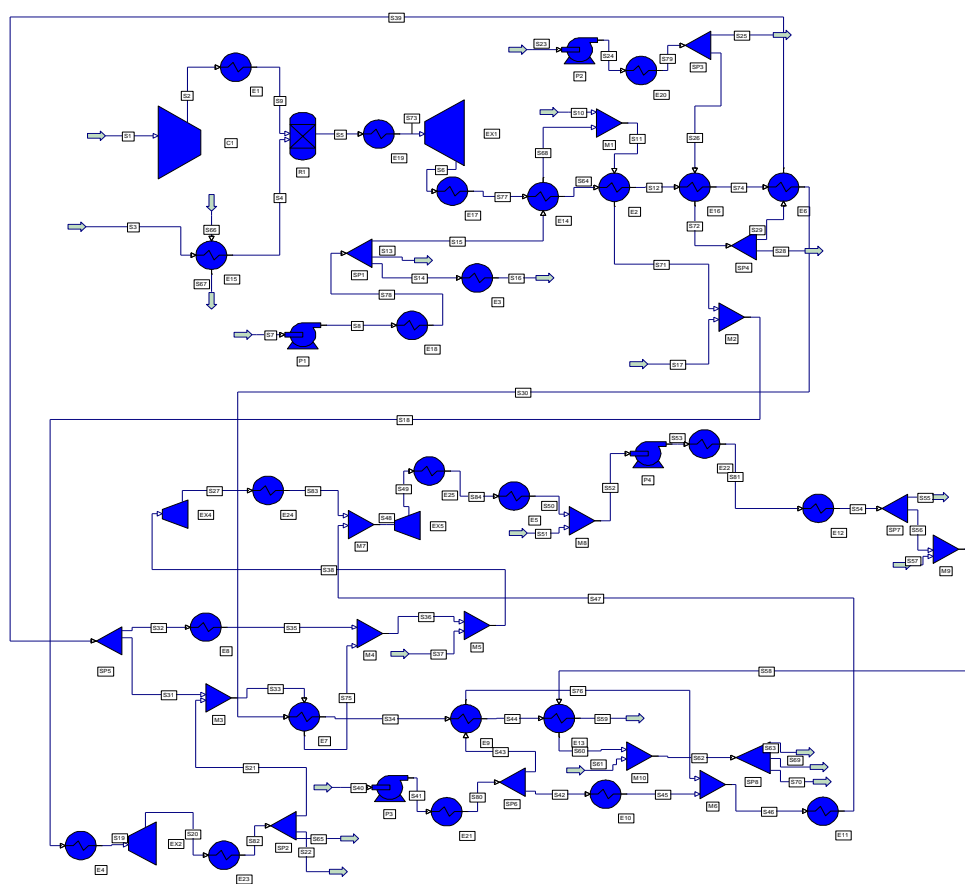

Figure 2: Simulation processes flow diagram of NGCC plant

Table 2: The compositions of nature gas

Compositions	Volume%
Methane	85.965
Ethane	7.55
Propane	5.42
I-Butane	0.47
n-Butane	0.48
Pentane	0.1
Nitrogen	0.015

Table 3: The compositions of syngas

Composition	mole%
H <sub>2</sub>	36
CO	54
CO <sub>2</sub>	8
N <sub>2</sub>	2

Table 3 shows the compositions of syngas which from coal gasification process. Chen et al. (2012) has reported a process analysis study of integrated gasification combined-cycle (IGCC) with CO<sub>2</sub> capture. To analyse the system performance of IGCC with CO<sub>2</sub> capture. There are four major blocks in a reference IGCC plant, i.e. air separation unit (ASU), gasification island, gas clean-up unit, and combined-cycle power block. Additional water gas shift reaction and CO<sub>2</sub> absorption processes are integrated into the gas clean-up system for CO<sub>2</sub> capture. The feedstock is Kaltim Prima Coal (KPC) from Indonesia, which is generally used in Taiwan, to evaluate the data with actual situation in Taiwan. The proximate and ultimate analyses are shown in table 4. The KPC is lower sulfur content and higher oxygen content. Therefore, the study refers the compositions of syngas in previous study. Table 5 shows the compositions of SNG. In the previous study (Chen et al., 2013, the system-level simulation model for SNG production from coal gasification was performed. The specified parameter "M" is adopted in the study to take the effect of CO<sub>2</sub> in methanation and the system efficiency. In general, the value of M is from 2.9 to 3.1 and best is 3. There are four major sections, i.e. air separation unit (ASU), gasification island, gas clean-up unit, and methanation processes, included in the synthetic natural gas production model, among which the first three are typical for gasification-based energy systems, while the fourth is specific for SNG production. The methanation process is adopted to convert syngas to methane. It consists of four methanation reactors with heat exchangers. The result shows that the specified parameter "M" is very important, and affects deeply the CH<sub>4</sub> production. Therefore, table 4 refers the compositions of SNG which the M is 2.97 in previous study.

Table 4: The proximate and ultimate analyses of KPC

Total Moisture % as received	10.5
Proximate Analysis % air dried basis	
Moisture	5
Ash	5
Volatile Matter	41
Fixed Carbon	49
Calorific Value kcal/kg	
Air dried	7,100
Gross as received	6,689
Net as received	6,389
Ultimate Analysis (DAF)%	
Carbon	80
Hydrogen	5.5
Nitrogen	1.6
Sulfur	0.7
Oxygen	12.2

Table 5: The compositions of SNG

Composition	mole%
H <sub>2</sub>	0.8
CO <sub>2</sub>	0.7
CH <sub>4</sub>	90.9
N <sub>2</sub>	7.6

Table 6: Basic case benchmark with the Dah-Tarn NGCC power plant

Item	Specification	Simulation Results
Gross gas turbine output (MW)	233.9	225.19
Gross steam turbine output (MW)	256.9	257.30
Gross output (MW):2GT+1ST	724.7	707.68

Table 7: The performances of the NGCC power plant with two difference fuels

Item	SNG	Mixture gas
Gross output (MW)	701.95	686.59
Gross efficiency (%)	57	55.75

#### 4. Results and Discussion

Table 6 shows the simulation results of basic case benchmark with the Dah-Tarn NGCC power plant. The gross gas turbine output is 225.19 MW, the gross steam turbine output is 257.30 MW. Total gross output is 707.68 MW with the configuration of two gas turbines and one steam turbine. The deviation of gross output is 2 % with the Dah-Tarn NGCC power plant.

Table 7 shows the performances of the NGCC power plant with two difference fuels. The results show that the system efficiency of pure SNG case is around 57 % (LHV). For the mixture gas case, the maximum ratio of syngas to SNG is 1:19, due to keep the same composition of methane is 85.9 % with the Dah-Tarn NGCC power plant. The efficiency of mixture gas case is 55.75 % (LHV).

#### 5. Conclusions

The study envisages two analyses as the basic and feasibility cases. The former is the benchmark case which is verified with the reference data of exist NGCC power plant located in Dah-Tarn, Taiwan. The Dah-Tarn NGCC power plant introduces the advanced M501G gas turbine from Mitsubishi Heavy Industries, Ltd. (MHI) and the system efficiency of the combined-cycle is 58.75 % (LHV). The latter introduces a feasibility study with advanced gas turbine and actual parameters in Taiwan. The SNG from carbonate fuel feed to M501G based combined-cycle is evaluated in the feasibility study cases first, and the mixture gas of SNG and syngas is also evaluated to compare the different of overall performance with the pure SNG case.

The results show that the system efficiency of pure SNG case is around 57 % (LHV). The efficiency of mixture gas case is 55.75 % (LHV).

The study shows the possibility way to use coal and reduce the CO<sub>2</sub> emission. The another advantage is the using of SNG could increases the usage of combined-cycle in Taiwan, due to the prices of natural gas is higher than coal in Taiwan and results in the higher idle capacity.

#### Acknowledgment

The authors are grateful to the Ministry of Science and Technology for the financial support of the code number NSC 103-2923-E-042A-001 -MY3.

#### References

- Arvidsson M., Heyne S, Morandin M, Harvey S., 2012, Integration Opportunities for Substitute Natural Gas (SNG) Production in an Industrial Process Plant, *Chemical Engineering Transactions*, 29, 331-336.
- British Petroleum, 2013, BP Statistical Review of World Energy, British Petroleum, UK.

- Bureau of Energy, 2012, Energy Statistical Hand Book 2012, Bureau of Energy, R.O.C., Taipei, Taiwan. (in Chinese)
- Chen P.C., Chiu H.M., Chyou Y.P., 2010, Process analysis study of integrated gasification combined-cycle with CO<sub>2</sub> capture, *Procedia Engineering*, 42, 1502-1513.
- Chen P.C., Chiu H.M., Chyou Y.P., 2013, Process Simulation Study of Coal to Synthetic Natural Gas (SNG) with Gasification Technology, 2013 AIChE Annual Meeting, November 3-8, 2013, San Francisco, USA.
- Er-rbib H., Bouallou C., 2013, Modelling and Simulation of Methanation Catalytic Reactor for Renewable Electricity Storage, *Chemical Engineering Transactions*, 35, 541-546
- Lei J., Chakib B., 2012, China's Thermal Electricity Production and Relative Carbon Dioxide Emissions for the period 2012-2020, *Chemical Engineering Transactions*, 29, 157-162.
- Mitsubishi Heavy Industries, Ltd (MHI), G-series Gas Turbine, <[www.mhi.co.jp/en/products/detail/g\\_series\\_gas\\_turbine.html](http://www.mhi.co.jp/en/products/detail/g_series_gas_turbine.html)> accessed 28.02.2013