



Crack simulation models in variable amplitude loading - a review

Luiz Carlos H. Ricardo

*Materials Technology Department, IPEN, University of São Paulo, Brazil, Instituto de Pesquisas Energéticas e Nucleares
Av. Lineu Prestes 2242 - Cidade Universitária - São Paulo - SP BRASIL- CEP: 05508-000.
lricardo@ipen.br*

Carlos Alexandre J. Miranda

*Nuclear Engineering Department, IPEN, University of Sao Paulo, Brazil, Instituto de Pesquisas Energéticas e Nucleares
Av. Lineu Prestes 2242 - Cidade Universitária - São Paulo - SP BRASIL- CEP: 05508-000*

ABSTRACT. This work presents a review of crack propagation simulation models considering plane stress and plane strain conditions. It is presented also a chronological different methodologies used to perform the crack advance by finite element method. Some procedures used to edit variable spectrum loading and the effects during crack propagation processes, like retardation, in the fatigue life of the structures are discussed. Based on this work there is no consensus in the scientific community to determine the best way to simulate crack propagation under variable spectrum loading due the combination of metallurgic and mechanical factors regarding, for example, how to select and edit the representative spectrum loading to be used in the crack propagation simulation.

KEYWORDS. Fatigue; Crack propagation simulation; Finite element method; Retardation.

INTRODUCTION

The most common technique for predicting the fatigue life of automotive, aircraft and wind turbine structures is Miner's rule [1]. Despite the known deviations, inaccuracies and proven conservatism of Miner's cumulative damage law, it is even nowadays being used in the design of many advanced structures. Fracture mechanics techniques for fatigue life predictions remain as a back up in design procedures. The most important and difficult problem in using fracture mechanics concepts in design seems to be the use of crack growth data to predict fatigue life. The experimentally obtained data is used to derive a relationship between stress intensity range (ΔK) and crack growth per cycle (da/dN). In cases of fatigue loaded parts containing a flaw under constant stress amplitude fatigue, the crack growth can be calculated by simple integration of the relation between da/dN and ΔK . However, for complex spectrum loadings, simple addition of the crack growth occurring in each portion of the loading sequence produces results that, very often, are more erroneous than the results obtained using Miner's rule with an S-N curve. Retardation tends to cause conservative results using Miner's rule when the fatigue life is dominated by the crack growth. However, the opposite effect generally occurs when the life is dominated by the initiation and growth of small cracks. In these cases, large cyclic strains, which might occur locally at stress raisers due to overload, may pre-damage the material and lower its resistance to fatigue.

The experimentally derived crack growth equations are independent of the loading sequence and depend only on the stress intensity range and the number of cycles for that portion of the loading sequence. The central problem in the successful utilization of fracture mechanic techniques applied to the fatigue spectrum is to obtain a clear understanding of



the influence of loading sequences on fatigue crack growth [2]. Investigations covering the effects of particular interest, after high overload, in the study of crack growth under variable-amplitude loading in the growth rate region, called crack growth retardation, seem to have little interest nowadays.

Stouffer & Williams [3] and other researchers show a number of attempts to model this phenomenon through manipulation of the constants and stress intensity factors in the Paris-Erdogan equation however little appears to have been done in the effort to develop a completely rational analysis of the problem. Probably, the only one reason that the existing models of retarded crack growth are not satisfactory is that these models are deterministic whereas the fatigue crack growth phenomenon shows strong random features. In addition, most of the reported theoretical descriptions of the retardation are based on data fitting techniques, which tend to hide the behavior of the phenomenon. If the retarding effect of a peak overload on the crack growth is neglected, the prediction of the material lifetime is usually very conservative [4]. Accurate predictions of the fatigue life will hardly become possible before the physics of the peak overload mechanisms is better clarified. According to the existing findings, the retardation is a physically very complicated phenomenon which is affected by a wide range of variables associated with loading, metallurgical properties, environment, etc., and it is difficult to separate the contribution of each of these variables [5].

CRACK PROPAGATION CONCEPTS

Irwin [6,7] defines in his work a release energy rate G , which is a measure of the available energy, $d\Pi$ -potential of energy and A -crack area, to provoke crack propagation as shown in Eq. (1). The term rate as employed is not related to a derivate in relation to the time but is referred to a change in the potential energy rate in the crack area. Later, this quantity has been called K , and is used to characterize the stress state ("stress intensity") near a crack tip caused by a remote load or residual stress in isotropic and elastic bodies. The stress field in the crack tip is given by Eq. (2),

$$G = \frac{d\Pi}{dA} \tag{1}$$

$$\sigma_{ij} = K(2\pi r)^{-1/2} f_{ij}(\Theta) + A_2 g_{ij}(\Theta) + A_3 h_{ij}(\Theta) r^{1/2} + \dots \tag{2}$$

where K is the stress intensity factor; r and Θ are the distance from the crack tip and the angle between the crack tip and the plane of the crack, respectively; A_i is a constant of the material; $f_{ij}(\Theta)$, $g_{ij}(\Theta)$ and $h_{ij}(\Theta)$ are functions of Θ . After years, the stress-intensity factors for a large number of crack configurations have been generated; and these have been collated into several handbooks (see, for example, Refs [8,9]). The use of K is meaningful only when small-scale yielding conditions exist. Plasticity and nonlinear effects will be covered in the next section. Because fatigue-crack initiation is, in general, a surface phenomenon, the stress-intensity factors for a surface- or corner-crack in a plate or at a hole, such as those developed by Raju and Newman [10,11], are solutions that are needed to analyze small-crack growth. Some of these solutions are used later to predict fatigue-crack growth and fatigue lives for notched specimens made of a variety of materials [12].

Frost and Dugdale [13] have evidenced that the size of the plastic zone increases in the same ratio that of the crack length. One can notice that the results of the equation depend linearly on the crack length a , however, Frost and Dugdale [13] also argued by dimensional analysis that the incremental propagation in the crack length da , for an incremental number of cycles dN , should be directly proportional to the crack length a . Thus,

$$\frac{da}{dN} = Ba \tag{3}$$

where B is a function of the applied stresses.

Paris & Erdogan [14] conducted a revision on the crack propagation approach from Head [15] and others and discussed the similarity of these theories and the differences of results between them, isolated and in group tests. Paris suggested that, for a cyclical load variation, the stress field in the crack tip for a cycle can be characterized by a variation of the stress intensity factor,

$$\Delta K = K_{\max} - K_{\min} \tag{4}$$

where K_{max} and K_{min} are the maximum and the minimum stress intensity factors, respectively. In the crack propagation curve, the linear part represents the Paris - Erdogan law, when plotting the values of ΔK vs da/dN in logarithmic scale. Fatigue crack initiation and growth under cyclic loading conditions is controlled by the plastic zones that result from the applied stresses and exist in the vicinity (ahead) of a propagating crack and in its wake or flanks of the adjoining surfaces. For example, the fatigue characteristics of a cracked specimen or component under a single overload or variable amplitude loading situations are significantly influenced by these plastic zones. In modelling the fatigue crack growth rate this is accounted by the incorporation of accumulative damage cycle after cycle and should include plasticity effects. During the crack propagation the plastic zone should grown and the plastic wake will have compressive plastic zones that can help to keep the crack close.

Prediction of the fatigue behaviour of structural components subjected to overloads and variable amplitude loading requires an estimation of the plastically affected regions ahead of the crack-tip. One of the most widely used plasticity models in fatigue is the Dugdale's yield strip model [16] In this model the plastically affected zone (r_y or r_p) is assumed to be small as shown Fig. 1.

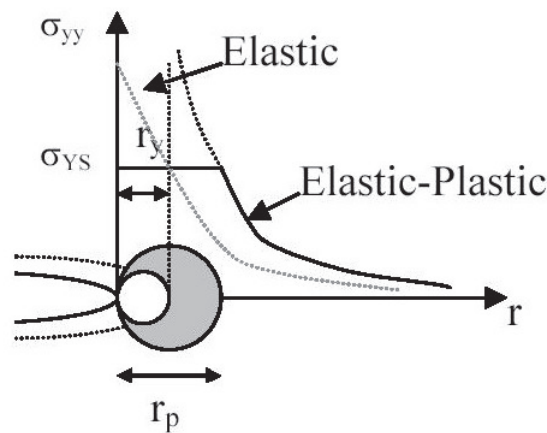

Figure 1: Elastic and Elastic-Plastic Zone Sizes.

Hairman & Provan [17] discuss the problems pertaining to fatigue loading of engineering structures under single overload and variable amplitude loading involving the estimation of plasticity affected zones ahead of the crack tip. The models of Irwin [6,7] and Dugdale [16] give an idea of the size of the plastic zone but not of its shape. The size, in general, is estimated as a circle of certain diameter (r_y or r_p) obtained on the basis of reasoning given in the above models for crack-tip-plasticity. In these models the effect of the shape of the plasticity affected zones is not taken into account.

To obtain a better idea of the plastic zone shape, the components of stress in the radial and circumferential directions of a mode-1 type of loading were derived using an eigenfunction expansion method developed by Williams [18] and with a modification to take into consideration crack-tip blunting. The resulting equations are:

$$\begin{bmatrix} \sigma_r \\ \sigma_\theta \\ \sigma_{r\theta} \end{bmatrix} = \begin{bmatrix} \frac{1}{4} \frac{K}{\sqrt{2\pi r}} \left(5 \cos\left(\frac{\theta}{2}\right) - \cos\left(\frac{3\theta}{2}\right) \right) + T_r + f(\rho, r, \theta) \\ \frac{1}{4} \frac{K}{\sqrt{2\pi r}} \left(3 \cos\left(\frac{\theta}{2}\right) + \cos\left(\frac{3\theta}{2}\right) \right) + f(\rho, r, \theta) \\ \frac{1}{4} \frac{K}{\sqrt{2\pi r}} \left(\sin\left(\frac{\theta}{2}\right) + \sin\left(\frac{3\theta}{2}\right) \right) + f(\rho, r, \theta) \end{bmatrix} \quad (5)$$

The first terms in Eq. (5) represent the singular terms as $r \rightarrow 0$ and are, therefore, dominant near the crack-tip. The second term in Eq. (5) arises from a consideration of higher power terms. This term is known as the T-stress, it is not singular as $r \rightarrow 0$ but it can affect the elastic-plastic crack-tip stress state. The third terms arise as a contribution from crack-tip blunting and are not given in Williams [18]. The contribution of crack-tip blunting has been discussed in Rolfe –



Barsom [19] and the contribution of this term is $\sigma_p = K / \sqrt{\pi\rho}$ for a sharp elliptic or hyperbolic notch with a crack-tip radius, ρ .

The above equations can now be used to obtain the principal stresses after the simplifying assumptions of negligible contributions of T_{rr} and $f(\rho, r, \theta)$ are assumed. Hence, the principal stresses, as derived from Eq. (5), become:

$$\begin{bmatrix} \sigma_1 \\ \sigma_2 \\ \sigma_3 \end{bmatrix} = \begin{bmatrix} \frac{K}{\sqrt{2\pi r}} \cos \frac{\theta}{2} \left(1 + \sin \frac{\theta}{2} \right) \\ \frac{1}{4} \frac{K}{\sqrt{2\pi r}} \cos \frac{\theta}{2} \left(1 - \sin \frac{\theta}{2} \right) \\ \nu(\sigma + \sigma_{21}) \\ 0 \end{bmatrix} \quad \begin{array}{l} \text{Plane Strain} \\ \text{Plane Stress} \end{array} \quad (6)$$

This, in conjunction with the von Mises and Tresca yield criteria, gives the expressions for the plastic zone shape as follows:

von Mises:

$$r_p(\theta) = \begin{cases} \frac{K^2}{4\pi\sigma_{ys}^2} \left(\frac{3}{2} \sin^2(\theta) + (1 - 2\nu)^2 (1 + \cos(\theta)) \right) & \text{Plane Strain} \\ \frac{K^2}{4\pi\sigma_{ys}^2} \left(1 + \frac{3}{2} \sin^2(\theta) + \cos(\theta) \right) & \text{Plane Stress} \end{cases} \quad (7)$$

Tresca:

$$r_p(\theta) = \begin{cases} \frac{K^2}{2\pi\sigma_{ys}^2} \cos\left(\frac{\theta}{2}\right) \sin^2\left(\frac{\theta}{2}\right) \\ \frac{K^2}{2\pi\sigma_{ys}^2} \cos^2\left(\frac{\theta}{2}\right) \left(1 - 2\nu + \sin\left(\frac{\theta}{2}\right) \right)^2 & \text{Plane Strain} \\ \frac{K^2}{2\pi\sigma_{ys}^2} \cos^2\left(\frac{\theta}{2}\right) \left(1 + \sin\left(\frac{\theta}{2}\right) \right)^2 & \text{Plane Stress} \end{cases} \quad (8)$$

$$\frac{da}{dN} = \frac{C(\Delta K)^m}{\left[(1 - K_{\min}/K_{\max}) K_c - \Delta K \right]}$$

$$\frac{da}{dN} = \frac{C(\Delta K)^m}{K_c - K_{\max}}$$

$$\frac{da}{dN} = C(K_{\max})^{1-m} (\Delta K)^m$$

Table 1: Empirical crack growth equations for constant amplitude loading [14].



In the original Paris crack propagation equation [14] the driving parameters are C , ΔK and m . In Tab. 1 it is possible to see some other crack propagation equations for constant amplitude loading, which are modifications of the Paris equation, relating the mentioned parameters.

Murthy et al. [20] discuss crack growth models for variable amplitude loading and the mechanisms and contribution to overload retardation. There are many authors which have been developing fatigue crack growth models for variable amplitude loading. Tab. 2 presents some authors and the application of their models.

Yield Zone Concept	Crack Closure Concept
Wheeler [21]	Elber [28]
Willenborg, Engle, Wood [22]	Bell and Creager (Generalized Closure) [29]
Porter [23]	Newman (Finite Element Method) [30]
Gray (Generalized Wheeler) [24]	Dill and Staff (Contact Stress) [31]
Gallagher and Hughes [25]	Kanninen, Feddersen, Atkinson [32]
Johnson [26]	Budiansky and Hutchinson [33]
Chang et al. [27]	de Koning [34]

Table 2: Fatigue crack growth models [20].

RETARDATION PHENOMENON

Corbly & Packman [35] present some aspects of the retardation phenomenon some of which are presented below.

1. Retardation increases with higher values of peak loading σ_{peak} for constant values of lower stress levels [36,37].
2. The number of cycles at the lower stress level required to return to the non-retarded crack growth rate is a function of ΔK_{peak} , ΔK_{lower} , R_{peak} , R_{lower} and number of peak cycles [38].
3. If the ratio of the peak stress to lower stress intensity factors is greater than 1.5 complete retardation at the lower stress intensity range is observed. Tests were not continued long enough to see if the crack ever propagated again [38].
4. With a constant ratio of peak to lower stress intensity the number of cycles to return to non-retarded growth rates increases with increasing peak stress intensity [37,38].
5. Given a ratio of peak stress to lower stress, the number of cycles required to return to non-retarded growth rates decreases with increased time at zero load before cycling at the lower level [38].
6. Increased percentage delay effects of peak loading given a percent overload are greater at higher baseline stress intensity factors [39].
7. Delay is a minimum if compression is applied immediately after tensile overload [40].
8. Negative peak loads cause no substantial influence of crack growth rates at lower stress levels if the values of $R > 0$ for the lower stress [41].
9. Negative peak loads cause up to 50 per cent increase in fatigue crack propagation with $R = -1$ [40].
10. Importance of residual compressive stresses around the tip of crack [42].
11. Low-high sequences cause an initial acceleration of the crack propagation at the higher stress level which rapidly stabilizes [43].

SMALL SCALE YIELD MODELS

While the basic layout of the small scale yield model has been established by Dill & Saff [44], only improvements introduced later by Newman [45] made this approach applicable to general variable amplitude loading. The small scale yield model employs the Dugdale [16] theory of crack tip plasticity modified to leave a wedge of plastically stretched material on the fatigue crack surfaces. The fatigue crack growth is simulated by severing the strip material over a distance corresponding to the fatigue crack growth increment as shown Fig. 2. In order to satisfy the compatibility between the elastic plate and the plastically deformed strip material, a traction must be applied on the

fictitious crack surfaces in the plastic zone ($a \leq x < a_{fict}$), as in the original Dugdale model, and also over some distance in the crack wake ($a_{open} \leq x < a$), where the plastic elongations of the strip $L(x)$ exceed the fictitious crack opening displacements $V(x)$.

The compressive stress applied in the crack wake to insure $L(x)=V(x)$ are referred to as the contact stresses. The fatigue crack growth is simulated using the strip material as shown schematically in Fig. 2.

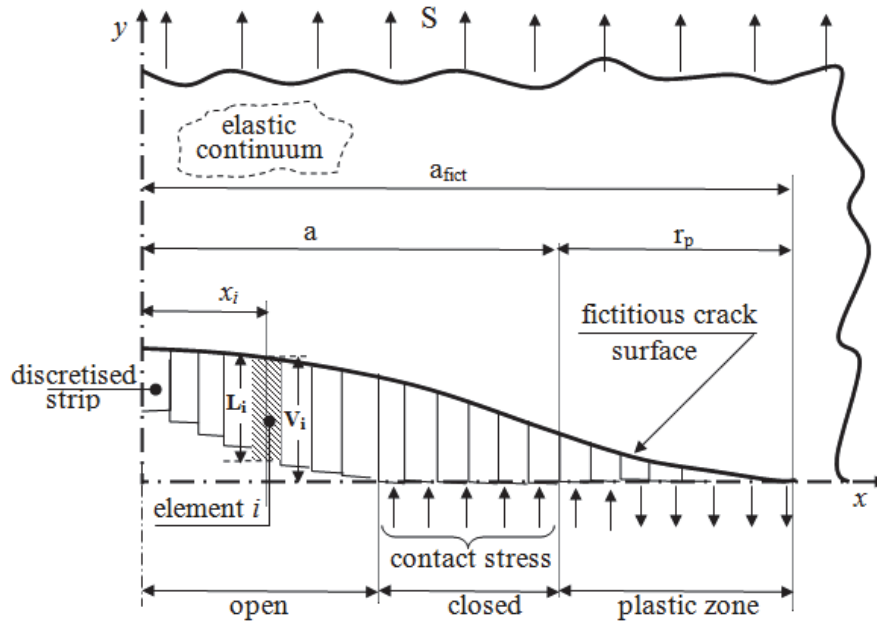

Figure 2: Schematic Small Scale Yield Model.

Ricardo et al. [46] discuss the importance in the determination of materials properties like crack opening and closing stress intensity factor. The development of crack closure mechanisms, such as plasticity, roughness, oxide, corrosion, and fretting product debris, and the use of the effective stress intensity factor range, has provided an engineering tool to predict small and large crack growth rate behavior under service loading conditions.

The major links between fatigue and fracture mechanics were done by Christensen [47] and Elber [48]. The crack closure concept put crack propagation theories on a firm foundation and allowed the development of practical life prediction for variable and constant amplitude loading, by such as experienced by modern day commercial aircrafts. Numerical analysis using finite elements has played a major role in the stress analysis crack problems. Swedlow [49] was one of the first to use finite element method to study the elastic-plastic stress field around a crack.

The application of linear elastic fracture mechanics, i.e. the stress intensity factor range, ΔK , to the “small or short” crack growth have been studied for long time to explain the effects of nonlinear crack tip parameters. The key issue for these nonlinear crack tip parameters is crack closure. Analytical models were developed to predict crack growth and crack closure processes like Dugdale [16], or strip yield, using the plasticity induced approach in the models considering normally plane stress or strain effects. Schijve [50], discussing the relation between short and long cracks presented also the significance of crack closure and growth on fatigue cracks under services load histories. The ultimate goal of prediction models is to arrive at quantitative results of fatigue crack growth in terms of millimeters per year or some other service period. Such predictions are required for safety and economy reasons, for example, for aircraft and automotive parts.

Sometimes the service load time history (variable amplitude loading) is much similar to constant amplitude loading, including mean load effects. In both cases quantitative knowledge of crack opening stress level S_{op} is essential for crack growth predictions, because ΔK_{eff} is supposed to be the appropriate field parameter for correlating crack growth rates under different cyclic loading conditions. The correlation of crack growth data starts from the similitude approach, based on the ΔK_{eff} , which predicts that same ΔK_{eff} cycles will produce the same crack growth increments. The application of ΔK_{eff} to variable amplitude loading require prediction of the variation of S_{op} , during variable amplitude load history, which for the more advanced prediction models implies a cycle by cycle prediction. The Fig. 3 shows the different K values.

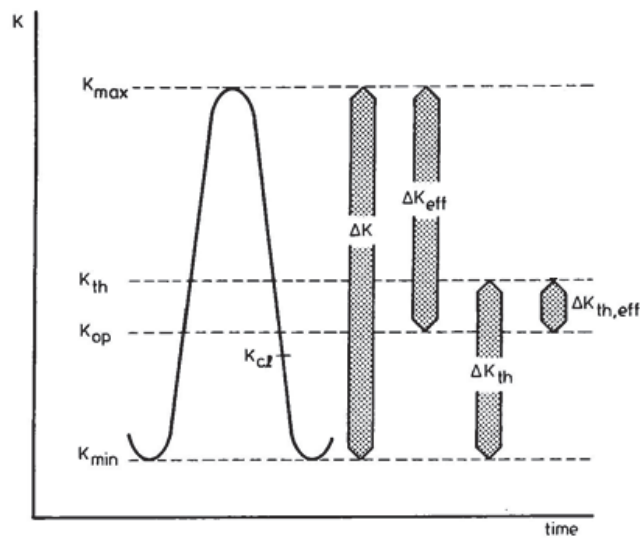

Figure 3: Definitions of K Values, Schijve [50].

The application of ΔK_{eff} is considerably complicated by two problems: (1) small cracks and (2) threshold ΔK values (ΔK_{th}). Small cracks can be significant because in many cases a relatively large part of the fatigue life is spent in the small crack length regime.

The threshold problem is particularly relevant for fatigue under variable amplitude spectrum, if the spectrum includes many “small” cycles. It is important to know whether the small cycles do exceed a threshold ΔK value, and to which extension it will occur. The application of similitude concept in structures can help so much, but the results correlation is not satisfactory and the arguments normally are:

- The similarity can be violated because the crack growth mechanism are no longer similar
- The crack can be too small for adopting K as a unique field parameter
- ΔK_{eff} and others conditions being nominally similar, it is possible that other crack tip aspects also affect crack growth, such as crack tip blunting and strain hardening, Schijve [50].

Newman and Armen [51-53] and Ohji et al. [54] were the first to conduct the two dimensional analysis of the crack growth process. Their results under plane stress conditions were in quantitative agreement with experimental results by Elber [28], and showed that crack opening stresses were a function of R ratio ($S_{\text{min}}/S_{\text{max}}$) and the stress level (S_{max}/σ_0), where σ_0 is the flow stress i.e: the average between σ_{ys} and σ_u .

Blom and Holm [55] and Fleck and Newman [56-57] studied crack growth and closure under plane-strain conditions and found that cracks did close but the cracks opening levels were much lower than those under plane stress conditions considering same loading condition. Sehitoğlu et al. [58] found later that the residual plastic deformations that cause closure came from the crack. McClung [59-61] performed extensive finite element crack closure calculations on small cracks at holes, and various fatigue crack growth models. Newman [62] found that S_{max}/σ_0 could correlate the crack opening stresses for different flow stresses (σ_0). This average value was used as stress level in the plastic zone for the middle crack tension specimen, McClung [61] found that K analogy, using K_{max}/K_0 could correlate the crack opening stresses for different crack configurations for small scale yielding conditions where $K_0 = \sigma_0 \sqrt{\pi a}$. (K -analogy assumes that the stress-intensity factor controls the development of closure and crack-opening stresses and that, by matching the K solution among different cracked specimens, an estimate can be made for the crack opening stresses).

Matos & Nowell [63] present a literature review of the phenomenon of plasticity-induced fatigue crack closure under plane strain conditions and mention that there are controversial topics concerning the mechanics of crack propagation. In general there is no consensus in the scientific community. Fleck [64] used finite elements to simulate plasticity induced crack closure under plane strain conditions and predicted that the nature of the closure process changes from continuous to discontinuous after a sufficient increment of crack growth. He suggested that closure involves only a few elements relatively distant from the current crack tip and the closure levels decay steadily as the crack grows beyond its initial length. In the limit, the closure would not occur at all. Tab. 3 presents an adapted chronologic review crack advance scheme from Matos & Nowell [63].



Year	Author	Node Release Scheme	Constraint	Target	Element Type
1985	Blom and Holm [55]	Maximum load	PStress; PStrain	COP and CCL	Triangle linear
1986	Fleck [64]	Maximum load	PStress; PStrain	COP	Triangle linear
1989	McClung and Sehitoglu [65]	Maximum load	PStress; PStrain	COP	Quadrilateral linear
1989	McClung et al. [66]	Maximum load	PStress; PStrain	COP	Quadrilateral linear
1991	Sun and Sehitoglu [67]	Maximum load	PStress; PStrain	COP	Quadrilateral linear
1992	Sehitoglu and Sun [68]	Maximum load; Minimum load	PStress; PStrain	COP	Quadrilateral linear
1996	Wu and Ellyin [69]	Maximum load	PStress	COP and CCL	Quadrilateral linear
1999	Ellyin and Wu [70]	Maximum load	PStress	COP and CCL	Quadrilateral linear
2000	Wei and James [71]	Maximum load	PStress; PStrain	COP and CCL	Triangle linear
2002	Ricardo et al. [72]	Minimum Load	PStress	COP and CCL	Triangle quadratic
2002	Pommier [73]	Minimum Load	PStrain	COP and CCL	Quadrilateral linear
2003	Ricardo [74]	Minimum Load	PStress	CCL	Triangle quadratic
2003	Solanki et al. [75]	Maximum load	PStress; PStrain	COP and CCL by COEL	Quadrilateral linear
2004	Solanki et al. [76]	Maximum load	PStress; PStrain	COP and CCL by COEL	Quadrilateral linear
2004	Zhao et al. [77]	Maximum load	PStrain	COP and CCL by CME	Quadrilateral linear
2005	Gonzalez-Herrera and Zapatero [78]	Maximum load	PStress; PStrain	COP and CCL by DME	Quadrilateral linear
2007	Matos & Nowell [79]	Minimum load	PStress	COP and CCL by COEL	Quadrilateral linear

PStress- plane stress; PStrain- plane strain; COP- crack opening; CCL- crack closing;
 COEL- crack opening and closing by contact element;
 CME- crack opening and closing by compliance method;
 DME- crack opening and closure by displacement method

Table 3: Chronological crack advance scheme.

In Singh et al. [80] the authors provide a review of some crack propagation issues. The paper cover the transients and single overload effects as well as the plasticity induced crack closure. In this topic Singh et al [80] presented a discussion regarding how the researchers normally work in crack propagation simulation considering overload-induced crack closure. Lei [81] determine the crack closure by finite element method in a compact specimen. In the work Lei [81] use ABAQUS [82] to perform the crack propagation simulation using the crack face method was good agreement with experimental data.

Ricardo et al. [72] present an example of small scale yielding under constant amplitude loading. A compact tension specimen was modeled using a commercial finite element code Ansys version 6.0 [83]. A half of the specimen was modeled and symmetry conditions were applied. Fig. 4 shows the compact tension specimen from ASTM 647-E95a [84]. A value of $19 \text{ MPa}\sqrt{\text{m}}$ was applied as an equivalent force using the expression (9) in the model. Fig. 5 shows the model used in this work and Fig. 6 shows an example of post-processing of the small scale yielding stress intensity factor.

$$P_{\max} = \frac{KBW}{f\left(\frac{a}{w}\right)} \quad (9)$$

where, K is the stress intensity factor; P_{\max} is the maximum applied load; B is the specimen thickness; a is the crack length; W is the specimen width; a/w is the crack length to width relation for the specimen and $f(a/W)$ is the characteristic function of the specimen that can be found in ASTM 647-E95a [84].

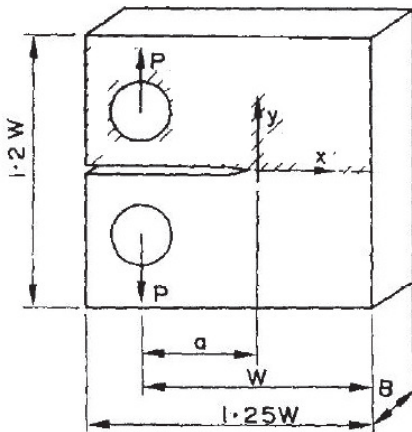

Figure 4: Compact Tension (CT) Specimen.

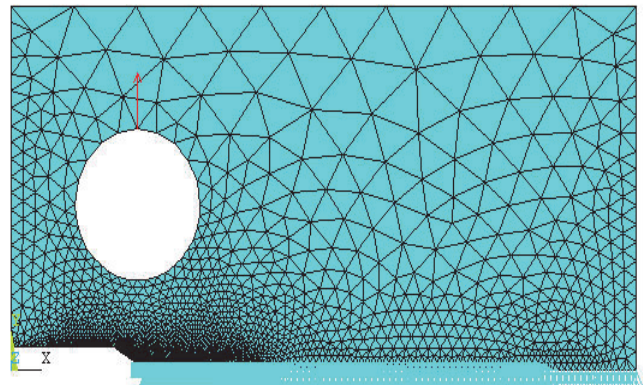

Figure 5: FEM Model of CT specimen.

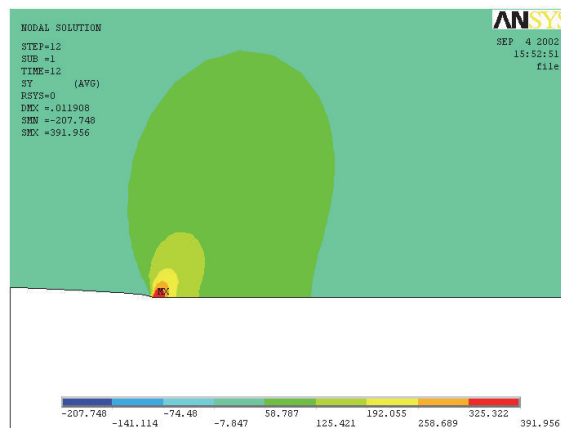

Figure 6: Post-Processing of Small Scale Yield Model.

GENERATION OF VARIABLE AMPLITUDE LOADINGS

Machniewicz [85-86] presents methodologies for fatigue crack growth models considering metallic materials. In the part I Machniewicz [85] present a review of crack growth predictions models and the deterministic models like AFGROW [87] and Willenborg et al. [22] models. Crack closures models are presented with their characteristics to apply under constant and variable amplitude loading. Machniewicz in part II [86] is presented the constraint factors normally used in plane stress constraint. FASTRAN [88] and NASGRO [89] are the most codes used in plane stress constrain to determine plastic strip stresses and strain.

Heuler & Klätshcke [90] discuss the procedure and how the generation of standards loadings can support the development of structures and components considering crack growth phenomenon under variable amplitude loading. It is well-known that data and models that characterize the fatigue behavior of materials and structures under baseline constant amplitude loading may not be appropriate or sufficient to adequately assess their fatigue performance under irregular



variable amplitude loading. Basic research is conducted under use of simplified load sequences such as single overload or underload or block loading with alternate mean loads.

Phenomena like crack growth retardation or acceleration are described making reference to base-line constant amplitude data. It is generally agreed, however, that real life load spectra also need to be applied in order to get a realistic picture of the relevance and significance of the mechanisms involved. Standardized load sequences or **L**oad-**t**ime **H**istories (SLH's) presently available provide an appropriate selection of load sequences to be used in the development of components, but they can also advantageously be used for other tasks. In this section it will be presented an overview on and a summarizing description of standardized load-time histories. With the need for optimum light-weight design, originally the aircraft industry was the main driver for these efforts. Two of the most well known SLH's are the TWIST [91] and FALSTAFF [92] sequences for transport and fighter aircraft, respectively, which have been and are still being applied for numerous studies on materials, joints and other structural elements.

For automotive applications, the CARLOS [93] series of SLH's have been presented including the very recent load sequence for car trailer couplings, CARLOS-TC. In the US, activities were mainly centered on the derivation of test load sequences to be used for evaluation and development of fatigue life prediction methodology. Bodies like the SAE Fatigue and Evaluation Committee took a pragmatic approach by selecting test load sequences from existing strain measurements, which were felt to be typical for the ground vehicle industry. Altamura & Straub [94] presents a work where discuss different ways to work with variable amplitude loading and the strategies to conduct fatigue analysis in structures. It is shown the methodology for discretization of random loads in blocks to be used in the development of components. And, also, it is presented the procedure to evaluate crack growth under constant and variable amplitude loading. Probabilistic fatigue crack growth is discussed as well the mathematics models available to use like Monte Carlos simulation. It is generally agreed that the structural load variations should be characterized in the time domain since in most cases the range (or amplitude) of a load, stress or strain cycle and its respective max or mean value can be considered as fatigue-relevant. Furthermore, the sequence or mixing of load cycles of different ranges and mean values must not be neglected. Analyses in the frequency domain give insight into the frequency content of a load signal which is particularly useful for flexible structures, but do not deliver the above-mentioned values. Many structural loading environments can be described as sequences of different modes [95] which may be a particular flight, driving a car on certain road types, a sea state of a given severity, etc. These modes of operation contain load cycles of different, but typical magnitudes and frequencies. Often distinct patterns of grouped load cycles can be distinguished, they are called a loading event or element, such as braking or cornering of a car, different flight phases or maneuvers of an aircraft.

Zheng [96] provides a criterion for omitting small loads. In past, the underload (or subload) was defined as the nominal stress amplitude lower than or equal to the endurance limit, and the underload effect on fatigue life was investigated experimentally by using smooth specimens. Test results showed that underload cycles applied to smooth specimens increased the fatigue life or the endurance limit of low-carbon steel [96] and cast iron [97], which was called "coaxing". However, past research on the underload effect was not associated with the omission of small load cycles in life prediction [98,99]. The omission of small load cycles is necessary and important in compilation of the load spectrum [100,101], once the accumulated damage will not affect the prediction of the fatigue life and the assessment of the fatigue reliability of structures [102,103], and it is most cost effective in fatigue tests of components and structures under long-term variable-amplitude or random loading histories [104]. Up to date, some empirical criteria have been proposed and used [105,106]. However, how to omit the small loads in life prediction by using the local strain approach was not clearly set forth [106]. In the discussion of the importance of crack growth under variable amplitude loading, Youb & Song [106], using results obtained from single edge crack bending (SEB), mentioned that Schijve [101] was one of the first works covering this topic. Kikukawa et al. [107] have extensively measured crack opening behavior under various random loadings and reported that crack opening point is controlled by the maximum range-pair load cycle (which we call hereafter "the largest load cycle") in a random load history and is identical to the crack opening result of constant amplitude loading corresponding to the largest load cycle. Based on this crack opening behavior, they proposed a simple prediction procedure for crack growth under random loading.

The phenomenon of plasticity-induced fatigue crack closure under plane strain conditions is one of the most controversial topics concerning the mechanics of crack propagation. No general consensus exists among the scientific community concerning the physical mechanism for crack closure under plane strain conditions. One of the problems is on how to prepare the mesh and the procedure used in crack propagation. With three-dimensional models it becomes necessary to use normal contact approach to node release; in plane stress, spring is normally used to help the crack propagation, using contact resources for crack propagation and considering material nonlinear analysis it will result in a big result file and will spend a considerable time processing to end the simulation. According to Fleck [108] the source of discontinuous closure appears to be a residual wedge of material on the crack flanks, located just ahead of the initial position of the crack tip.

More recently Wei and James [109] reported that after growing a virtual plane strain fatigue crack for a few cycles, there is no contact in the region immediately behind the crack tip and the contact pressure along the crack faces is discontinuous. Zao et al. [110] modelled a CT specimen under plane stress and plane strain. They did not observe plasticity-induced crack closure under plane strain during steady state crack growth under cyclic tension, although they found significant levels of closure under plane stress.

Solanki et al. [75] present a review of crack propagation in plane stress and plane strain conditions. A M(T) specimen was modeled with an externally induced T -stress to observe the subsequent change in closure levels under plane-strain. A T-stress was induced by applying tractions parallel to the crack in addition to the conventional tractions perpendicular to the crack. Fig. 7 shows the variation in the crack tip plastic zone size accordingly with mesh. Fig. 8 shows the difference of result in node release at minimum and maximum load compared by Solanki et al. [76].

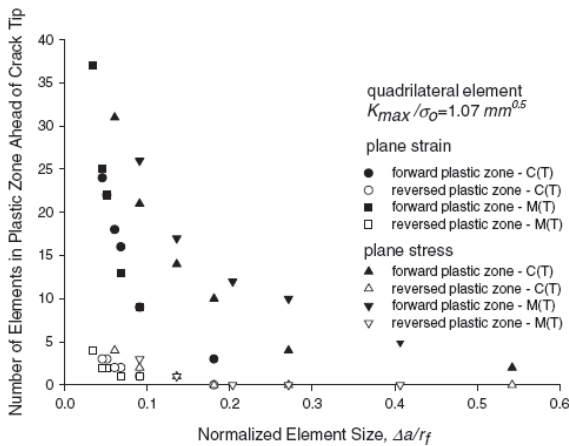

Figure 7: Variation in Crack Tip Plastic Zone Size with Mesh [75].

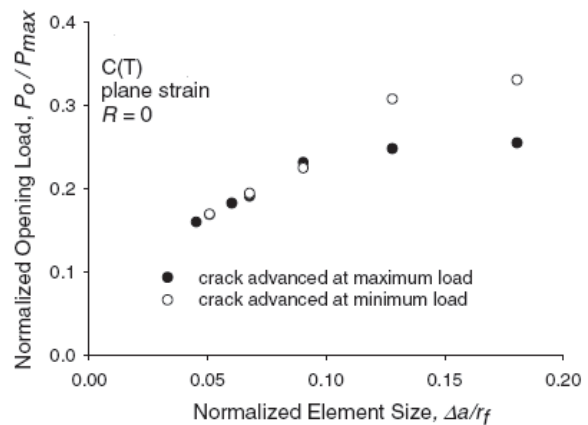

Figure 8: Comparison of Crack opening values based on crack advance scheme [75].

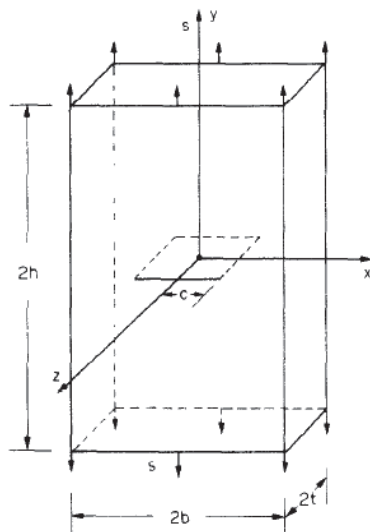

Figure 9: Middle-Crack Tension Specimen Subjected to uniform stress [112].

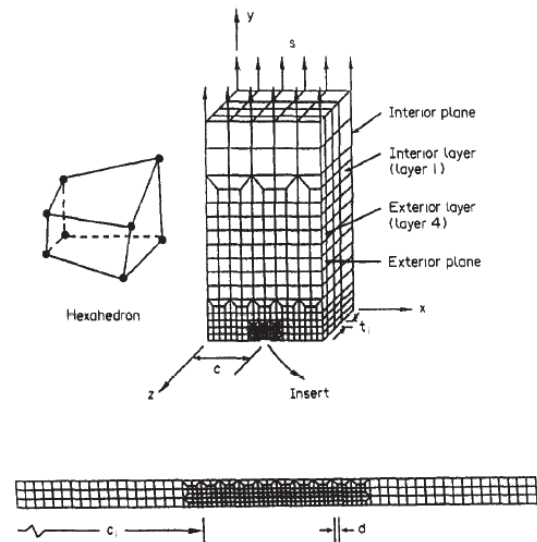

Figure 10: Crack Propagation Model Quarter of Middle Tension [113].

Chermahini [111] present some crack propagation analyses using 3D model and plane strain model to determine the crack opening level. On the specimen surface and in the mid-plane the crack-opening stress levels tend to be two-dimensional solutions for plane stress and plane strain conditions, respectively. Fig. 9 shows the geometry used by Chermahini et al. [112].



In Fig. 10, it is possible to see the finite element model used for crack propagation elaborated by Wu & Ellyin [113]. The model was prepared using layers of elements, considering the size of the smaller elements in the reverse plastic zone computed by Irwin equation and then increasing the size of the hexahedron elements until arriving the region where the results will not affect the stress level in the crack propagation area. Spring elements were used for node release, cycle after cycle, as in Newman [45].

Wu and Ellyin [113] had used a truss element together with pairs of contact elements and the element death option for crack propagation simulation. This technique used in plane stress and plane strain models is usual in commercial finite element codes. The element death option was incorporated to remove truss elements. With their approach, a node can be released any time during a load cycle irrespective of the magnitude of the deformation caused by the release of the node. Consequently, fewer problems with convergence were encountered and also several nodes could be released simultaneously if desired.

CONCLUSIONS

The paper provides a review of some crack retardation models under variable amplitude loadings. It was discussed, also, the small scale yield model using finite element method. The Miner's rule crack initiation approach can be conservative in some applications, in special if the structures should develop cracks under variable amplitude loading. It is presented the standards loadings histories normally used in automotive and aeronautics structures. Several crack advance schemes are presented and it is possible to observe that there is no agreement in the science community about the best strategy to edit experimental signals to be applied in numerical models aiming to obtain good correlation between numerical and experimental data. The crack propagation simulation under constant amplitude loading in plane stress has good agreement with experimental data. Plane strain need complex models with large number of nodes and it is necessary to define and work with contact between the crack surfaces and, therefore, perform nonlinear analysis to identify when the crack open or close.

Regarding variable amplitude loading until the moment the authors do not identify a consistent methodology and procedure for crack propagation simulation. The problem should be related with the random fatigue phenomenon and to determine when the crack opens or closes, either using experimental or numerical data, is a challenge to be achieved. The computers are improving their processing and storage capacity with possibility to increase the size of models and decreasing the element size becoming more realistic the crack propagation simulation. In the near future it will be necessary to perform more and more tests to validate the numerical models hoping that the correlation between numerical and experimental results becomes better and better.

REFERENCES

- [1] Miner, M. A., Cumulative damage in fatigue, *Journal of Applied Mechanics*, ASME, USA, 12 (1945) A159-A164.
- [2] Schijve, J., Fatigue crack propagation in light alloy sheet material and structures, NLR, Report MP195, Amsterdam (1960).
- [3] Stouffer, D. C. , Williams, J. F., A method for fatigue crack growth with a variable stress intensity factor, *Eng. Fracture Mechanics*, 11, (1979), 525-536. DOI: 10.1016/0013-7944(79)90076-6.
- [4] Ditlevsen, O., Sobczyk, K., Random fatigue crack growth with retardation, *Eng. Fracture Mech.*, 24(6) (1986) 861-878. DOI:10.1016/0013-7944(86)90271-7
- [5] Wei, R. P., Shih, T. T., Delay in fatigue crack growth, *Int. Journal Fracture*, 10 (1974) 77-85. DOI: 10.1007/bf00955082
- [6] Irwin, G. R., *Journal of Applied Mechanics*, 79 (1953) 361.
- [7] Irwin, G. R., *Journal of Basic Engineering, Trans., ASME, series D*, 82(2) (1960) 417. DOI: 10.1115/1.3662608
- [8] Tada, H., Paris, P.C, Irwin, G.R., *The stress analysis of cracks handbook*, Bethlehem, PA, Del Research Corporation, USA,(1985).
- [9] Murakami, Y., editor. *Stress intensity factors handbook*. New York: Pergamon Press, USA (1987).
- [10] Raju I.S., Newman JC Jr. Stress-intensity factors for a wide range of semi-elliptical surface cracks in finite-thickness plates, *Eng. Fracture Mechanics*, 11 (1979) 817-829. DOI: 10.1016/0013-7944(79)90139-5.



- [11] Newman, J.C. Jr., Raju, I., Stress-intensity factor equations for cracks in three-dimensional finite bodies subjected to tension and bending loads, *Computational Methods in the Mech. of Fracture*. In: Atluri SN, editor. Amsterdam: Elsevier, (1986) 311-334. DOI: 10.1002/zamm.19870671132.
- [12] Newman, J. C., The merging of fatigue and fracture mechanics concepts: a historical perspective, *Progress in Aerospace Sciences*, 34 (1998) 347-390. DOI:10.1016/s0376-0421(98)00006-2.
- [13] Frost, N. E., Dugdale, D. S., *Journal of Mechanics and Physics of Solids*, 6(2) (1958) 92-110. DOI:10.1016/0022-5096(58)90018-8.
- [14] Paris, P. C., Erdogan, F., *Journal of Basic Engineering*, 85 (1963) 528.
- [15] Head, A. K., *The Philosophical Magazine*, 44(7) (1953) 253.
- [16] Dugdale, D. S., Yielding of steel sheets containing slits, *J. Mech. Phys. Solids*, 8(2) (1960) 100-104. DOI:10.1016/0022-5096(60)90013-2.
- [17] Hairman, G. A., Provan, J. W., Fatigue crack tip plasticity revisited, *The Issue of Shape Addressed, Theoretical and Appl. Frac. Mech. Journal*, 26 (1997) 63-79. DOI: 10.1016/s0167-8442(96)00036-5.
- [18] Williams, M. L., On the stress distribution at base stationary crack, *Journal of Applied Mechanics*, 24 (1957) 111-114.
- [19] Rolfe, S. T., Barsom, J. M., *Fracture and fatigue control in structures – applications of fracture mechanics*, Prentice - Hall, New Jersey, (1977). DOI: 10.1520/MNL41-3RD-EB.
- [20] Murthy, A. R. C.; Palani, G. S., Iyer, N. R., State of art review on fatigue crack growth analysis under variable amplitude loading, *IEI Journal*, (2004) 118-129.
- [21] Wheeler, O. E., Spectrum loading and crack growth, *Transactions of the ASME Series D', Journal of Basic Engineering*, 94 (1972) 181-186.
- [22] Willenborg, J. D.; Engle, R. M., Wood, H. A., A crack growth retardation model using an effective stress concept, AFFDL, TM-71-FBR, Air Force Flight Dynamics Laboratory, Wright Patterson Air force Base, OH, (1971).
- [23] Porter, T. R., Method of analysis and prediction of variable amplitude fatigue crack growth, *Eng. Fracture Mechanics* 4(4) (1972) 717-736. DOI:10.1016/0013-7944(72)90011-2.
- [24] Gray, T. D., Gallagher, J. P., Predicting fatigue crack retardation following a single overload using a modified Wheeler model, *ASTM STP 590*, (1976). DOI: 10.1520/STP590-EB.
- [25] Gallagher, J. P., Hughes, T. F., Influence of the yield strength on overload fatigue crack growth behavior of 4340 steel, AFFDL – TR-74-27, Air Force Flight Dynamics Laboratory, Wright Patterson Air force Base, OH, (1974).
- [26] Johnson, W. S., Multi-parameter yield zone model for predicting spectrum crack growth, *ASTM STP 748*, (1981) 85-102. DOI: 10.1520/E0748-02R08 .
- [27] Chang, J. B., Hiyama, R. M., Szamossi, M., Improved methods for predicting spectrum loadings effects, AFWAL-TR-81-3092, Air Force Flight Dynamics Laboratory, Wright Patterson Air force Base, OH, (1984).
- [28] Elber, W., The significance of fatigue crack closure, *ASTM STP 486*, (1971) 230- 242. DOI: 10.1520/STP486-EB.
- [29] Bell, P. D., Creager, M., Crack growth analyses for arbitrary spectrum loading, AFFDL-TR-74-129, Air Force Flight Dynamics Laboratory, Wright Patterson Air force Base, OH, (1974).
- [30] Newman, J. C., A finite element analysis fatigue crack closure, NASA TM X 72005, NASA, Hampton, VA, (1975).
- [31] Dill, H. D., Saff, C. R., Spectrum crack growth prediction method based on crack surface displacement and contact analyses, *Fatigue crack growth under spectrum loads*, *ASTM STP 595*, (1976) 306–319. DOI: 10.1520/STP595-EB.
- [32] Kanninen, M. F., Atkinson, C., Feddersen, C. E., A fatigue crack growth analysis method based on a single representation of crack tip plasticity, *ASTM STP 637*, (1977) 122-140. DOI: 10.1520/STP637-EB.
- [33] Budianski, B., Huchthinson, J. W., Analysis of closure in fatigue crack growth, *Journal of Applied Mechanics*, 45 (1978) 267-276. DOI 10.1115/1.34.24286.
- [34] de Koning, A. U., A Simple crack closure model for predictions of fatigue crack growth rates under variable amplitude loading, *ASTM STP 743*, (1981) 63-85. DOI: 10.1520/STP743-EB.
- [35] Corbly, D. M., Packman, P. F., On The influence of single and multiple peak overloads on fatigue crack propagation in 7075-T6511 aluminum, *Eng. Fracture Mech.*, 5 (1973) 479-497. DOI:10.1016/0013-7944(73)90034-9.
- [36] Schijve, J., Brock, D., de Rigne, P., NLR, Report M2094, Amsterdam, (1962).
- [37] Hardrath, H. F., McEvily, A . T., In: *Proc. Crack propagation symposium*, Cranfield, 1 (1961).
- [38] Jonds, D., Wei, R. P., An exploratory study of delay effects in fatigue crack growth, *Int. J. Fracture Mechanics*, 7 (1971).
- [39] von Ewu, E., Hertzberg, R., Roberts, R., Delay defects in fatigue crack propagation, *nat. symposium F.M.*, (1971) 7.
- [40] Hudson, C. M., Effect of stress ratio on fatigue-crack growth in 7075-T6 and 2024-T3 alumina-alloy specimens. TNL-5390, NASA, (1969).
- [41] Crooker, T. W., Effect of T. C., Cycling on fatigue grade growth in high strength alloys, *NRL Report 7220*, (1971).



- [42] Hudson, C.M., Hardrath, H. F., Effects of changing stress amplitude on the rate of fatigue-crack propagation in two aluminum alloys, NASA TN D-960, September, (1961).
- [43] Mcmillan, J. C., Pelloux, R. M., ASTM STP 415, (1966) 505. DOI: 10.1520/STP415-EB
- [44] Dill, H. D., Saff, C. R., Spectrum crack growth prediction method based on crack surface displacement and contact analyses, *Fatigue crack Growth under Spectrum Loads*, ASTM STP 595, (1976) 306–319. DOI: 10.1520/STP595-EB.
- [45] Newman Jr, J. C., A Crack closure model for predicting fatigue crack growth under aircraft spectrum loading. In: Chang JB, Hudson CM, editors. *Methods and models for predicting fatigue crack growth under random loading*, ASTM STP 748, (1981) 53–84. DOI: 10.1520/STP748-EB
- [46] Ricardo, L. C. H., Pimenta, P. M., Spinelli, D., Crack closure simulation by finite element. In, Blom, A.F. ,*Fatigue* 2002, 4/5 (2002) 2293 – 2300.
- [47] Christensen, R. H., Fatigue Crack growth affected by metal fragments wedged between opening closing crack surface, *Appl. Mater. Res.*, 2 (1963) 207-210.
- [48] Elber W., Equivalent constant amplitude concept for fatigue crack growth under spectrum loading, ASTM STP 595, (1976) 236-250. DOI: 10.1520/STP595-EB
- [49] Swedlow, J. L., Effects and plastic flow in cracked plates, PhD Thesis, California Institute of Technology, Pasadena, USA, (1965).
- [50] Schijve, J., Observations on the prediction of fatigue crack growth propagation under variable amplitude loading, ASTM STP 595, (1976) 3-23. DOI: 10.1520/STP595-EB.
- [51] Newman J. C. Jr., Finite element analysis of fatigue crack propagation, including the effect C-(T) of crack closure, PhD Thesis, Virginia Polytechnic Institute, (1974).
- [52] Newman, J. C. Jr.; Armen, H. Jr. Elastic-plastic analysis of fatigue crack under cyclic loading, *AIAA Journal*, 13 (1975) 1017-1023. DOI: 10.2514/3.60499.
- [53] Newman, J. C. Jr., A finite element analysis of fatigue crack closure, ASTM 490, (1976) 281-301. DOI: 10.1520/STP490-EB.
- [54] Ohji, K., Ogura, K. Ohkubo, Y., Cyclic analysis of a propagation crack and its correlation with fatigue crack growth; *Eng. Fracture Mechanics*, 7 (1975) 457-464. DOI: 10.1016/0013-7944(75)90046-6.
- [55] Blom, A. F., Holm. D. K., An experimental and numerical study of crack closure; *Eng. Fracture Mechanics*, (1985) 907-1011. DOI: 10.1016/0013-7944(85)90039-6.
- [56] Fleck, N. A., Finite element analysis of plasticity induced crack closure under plane strain conditions, *Eng. Fracture Mechanics*, 25 (1986) 441-449. DOI:10.1016/0013-7944(86)90258-4.
- [57] Fleck, N. A., Newman, J. C. Jr, Analysis of crack closure under plane strain conditions , ASTM STP 982, (1988) 319-341. DOI: 10.1520/STP982-EB.
- [58] Sehitoglu, H. Gall, K., Garcia, A. M., Recent advances in fatigue crack growth modeling, *Int. Journal of Fracture*, 80(2) (1996) 165-192. DOI: 10.1007/BF00012668.
- [59] McClung, R. C., Sehitoglu, H., Finite element analysis of fatigue crack closure – numerical results, *Eng. Fracture Mechanics*, 33 (1989) 253–272. DOI: 10.1016/0013-7944(89)90028-3.
- [60] McClung, R. C., Finite element modeling of fatigue crack growth – theoretical concepts and numerical analysis of fatigue, In: Blom A, Beevers, C. Editors, West Midlands, Emas, (1992) 153-172.
- [61] McClung, R. C., Finite Element Analysis of Specimen Geometry Effects on Fatigue Crack Closure, *Fatigue Fract. Eng. Mater. Structures*, 17 (1994) 861-872. DOI: 10.1111/j.1460-2695.1994.tb00816.x.
- [62] Newman, J. C. Jr., A Finite element analysis of fatigue crack closure, ASTM 490, (1972) 281-301. DOI: 10.1520/STP490-EB.
- [63] Matos, P. F. P., Nowell, D., Numerical simulation of plasticity induced fatigue crack closure with emphasis on the crack growth scheme: 2D and 3D analyses, *Eng. Fracture Mechanics*, 75 (2008) 2087-2114. DOI: 10.1016/j.engfracmech.2007.10.017.
- [64] Fleck, N. A., Finite element analysis of plasticity-induced crack closure under plane strain conditions, *Eng. Fracture Mechanics*, 25(4) (1986) 441–449. DOI: 10.1016/0013-7944(86)90258-4.
- [65] McClung, R. C., Sehitoglu, H., On the finite element analysis of fatigue crack closure 1. basic modeling issues. *Eng. Fracture. Mechanics*, 33 (2) (1989) 237–252. DOI: 10.1016/0013-7944(89)90027-1.
- [66] McClung, R. C., Sehitoglu H., On the finite element analysis of fatigue crack closure 2. numerical results. *Eng. Fracture. Mechanics*, 33(2) (1989) 253–272. DOI: 10.1016/0013-7944(89)90028-3.
- [67] Sehitoglu, H., S Wei, Modelling of plane strain fatigue crack closure. *J. Eng. Mater. Technol*, 113 (1991) 31–40. DOI :10.1115/1.2903380.



- [68] Sun, W., Sehitoglu, H., Residual stress fields during fatigue crack growth, *Fatig. Fract. Eng. Mater. Struct.*, 15(2) (1992) 115–128. DOI: 10.1111/j.1460-2695.1992.tb00042.x.
- [69] Wu, J., Ellyin, F., A study of fatigue crack closure by elastic-plastic finite element analysis for constant-amplitude loading. *Int. Journal of Fracture*, 82 (1996) 43–65. DOI:10.1007/bf00017863.
- [70] Ellyin, F., Wu, J., A numerical investigation on the effect of an overload on fatigue crack opening and closure behavior, *Fatig. Fract. Eng. Mater. Struct.*, 22 (1999) 835–847. DOI: 10.1046/j.1460-2695.1999.00223.x.
- [71] Wei, L. W., James, M. N., A study of fatigue crack closure in polycarbonate CT specimen., *Eng. Fracture Mechanics*, 66 (2000) 223–242. DOI: 10.1016/s0013-7944(00)00014-x.
- [72] Ricardo, L. C. H., Pimenta, P. M., Spinelli D., Andrade, A. H. P., Crack closure simulation by finite element method; In: Blom, A. F (Ed.), *Fatigue 2002*, Emas Publishing, Stockholm, Sweden, 4 (2002) 2863-2869.
- [73] Pommier S., Plane strain crack closure cyclic hardening, *Eng. Fracture Mechanics*, 69(3) (2002) 25–44. DOI:10.1016/s0013-7944(01)00061-3.
- [74] Ricardo, L. C. H., Modeling fatigue crack opening and closing phenomenon by finite element method, PhD Thesis, Department of Structures and Foundations, University of Sao Paulo (In portuguese), (2003).
- [75] Solanki, K., Daniewicz, S. R., Newman, Jr J. C., Finite element modelling of plasticity-induced crack closure with emphasis on geometry and mesh refinement effects. *Eng. Fracture Mechanics*, 70 (2003) 1475–89. DOI:10.1016/s0013-7944(02)00168-6.
- [76] Solanki, K., Daniewicz, S. R., Newman, Jr J. C., A new methodology for computing crack opening values from finite element analyses, *Eng. Fracture Mechanics*, 71 (2004) 1165–1175. DOI:10.1016/S0013-7944(03)00113-9.
- [77] Zhao, L. G., Tong, J., Byrne, J., The evolution of the stress–strain fields near a fatigue crack tip and plasticity-induced crack closure revisited, *Fatig. Fract. Eng. Mater. Struct.*, 27(1) (2004) 19–29. DOI: 10.1111/j.1460-2695.2004.00716.x.
- [78] Gonzalez-Herrera, A., Zapatero, J., Influence of minimum element size to determine crack closure stress by finite element method, *Eng. Fracture Mechanics*, 72 (2005) 337–355. DOI:10.1016/j.engfracmech.2004.04.002.
- [79] Matos, P.F.P., Nowell D., On the accurate assessment of crack opening and closing stresses in plasticity-induced crack closure problems, *Eng. Fracture Mechanics*, 74(10) (2007) 1579–1601. DOI: 10.1016/j.engfracmech.2006.09.007.
- [80] Singh, K.D., Parry, M.R., Sinclair, I., Variable amplitude fatigue crack growth behavior – a short overview, *Journal of Mechanical Science and Technology*, 25(3) (2011) 663-673. DOI: 10.1007/s12206-011-132-6.
- [81] Lei, Y., Finite element crack closure analysis of a compact tension specimen, *International Journal of Fatigue*, 30 (2008) 21–31. DOI:10.1016/j.ijfatigue.2007.02.012.
- [82] ABAQUS, V6.3, Hibbitt, Karlsson & Sorensen, Inc., Providence, RI, (2002).
- [83] Ansys Inc, Ansys Version 6.0, USA, (2002).
- [84] ASTM, Standard test method for measurement of fatigue crack growth rates, E647–95a, (1995). DOI: 10.1520/E0647-15.
- [85] Machniewicz, T., Fatigue crack growth prediction models for metallic materials, part I: overview of prediction concepts, *Fatigue Fract Engng Mater Struct*, 36 (2012) 293–307. DOI: 10.1111/j.1460-2695.2012.01721.x.
- [86] Machniewicz, T., Fatigue crack growth prediction models for metallic materials, Part II: Part II: Strip yield model – choices and decisions, *Fatigue Fract Engng Mater Struct*, 36 (2012) 361–373. DOI: 10.1111/ffe.12009.
- [87] Harter, J. A. AFGROW users guide and technical manual. Air Force Research Laboratory, Report No. AFRL-VA-WP-TR-2006-XXXX, (2006).
- [88] Newman, J. C. FASTRAN II – A fatigue crack growth structural analysis program. NASA Technical Memorandum No. 104159. NASA Langley Research Center, Hampton, (1992).
- [89] Ten Hoeve, H. J., de Koning, A. U., Reference manual of the strip yield module in the NASGRO or ESACRACK software for the prediction of retarded crack growth and residual strength in metal materials, Report No. NLR TR 97012 L, NLR, Amsterdam, The Netherlands, (1997).
- [90] Heuler, P., Klätschke, H., Generation and use of standardized load spectra and load- times histories, *International Journal of Fatigue*, 27 (2005) 974-990. DOI: 10.16/j.ifatigue.2004.09.012.
- [91] Schütz, D., Lowack, H., de Jonge J. B., Schijve, J., A standardized load sequence for flight simulation tests on transport aircraft wing structures, LBF Report FB 106, NRL- Report TR 73, (1973).
- [92] Aircher, W., Branger, J., van Dijk, G. M., Ertelt J., Hück, M., de Jonge J. B., Description of a fighter aircraft loading for standard for fatigue evaluation FALSTAFF, Common Report of FCW Emmen, LBF, NRL, IABG, (1976).
- [93] Schütz, D., Klätschke, H., Steinhilber, H., Heuler, P., Schütz, W., Standardized load Sequences for car wheel suspension components, car loading standard- CARLOS, Fraunhofer Institute für Betriebsfestigkeit (LBF), Darmstadt, Industrieanlagen – Betriebsgesellschaft MBH (IABG), Ottobrunn, LBF – Report No FB- 191, (1999).



- [94] Alessandra A., Straub, D., Reliability assessment of high cycle fatigue under variable amplitude loading: Review and solutions, *Eng. Fracture Mechanics*, 121–122 (2014) 40–66. DOI:10.1016/j.engfracmech.2014.02.023.
- [95] Ten Have, A. A., European approaches in standard spectrum development, In: Potter J. M., Watanable R. T., editors, *Development of Fatigue Loading Spectra*, ASTM-STP 1006, ASTM, (1989) 35-75. DOI: 10.1520/STP1006-EB.
- [96] Zheng, X., On some basic problems of fatigue research in engineering, *International Journal of Fatigue*, 23 (2001) 751-766. DOI:10.1016/S0142-1123(01)00040-8.
- [97] Frost, N. E., Marsh, K. J., Pook, L. In: *Metal fatigue*, Oxford: Clarendon Press, (1974) 20-22.
- [98] Heuler, P., Seeger, T., A criterion for omission of variable amplitude loading histories, *International Journal of Fatigue*, 8(4) (1986) 225-230. DOI:10.1016/0142-1123(86)90025-3.
- [99] ECCS Recommendations for fatigue design of steel structures, Institute of Metal Construction (IOCM) of Swiss Federal Institute of Technology, Lausanne, Switzerland, ECCS, (1985).
- [100] Shi, Y. J., Yan, Y. M., Li, Z. R. Shi, Z. J., Hou, W. W., Assessment of remaining life of steel beams of Chang-Tai-Guam bridge on the line from Beijing to Guangzhou, Technical Report, Beijing, Institute of Railway Engineering, Chinese Academy of Railway Science, (1990).
- [101] Schijve, J., Observations on the prediction of fatigue crack growth propagation under variable amplitude loading, *ASTM STP 595*, (1976) 3-23. DOI: 10.1520/STP595-EB.
- [102] Barsom, J. M., Fatigue crack growth under variable amplitude loading in various bridge steels, *ASTM STP 595*, (1976) 217-235. DOI: 10.1520/STP595-EB.
- [103] Hudson, C. M., A root mean square approach for predicting fatigue crack growth under random loading, *ASTM STP 748*, (1981) 41-52. DOI: 10.1520/STP748-EB.
- [104] Johnson, W. S., Multi-parameter yield zone model for predicting spectrum crack growth, *ASTM STP 748*, (1981) 85-102. DOI: 10.1520/STP748-EB.
- [105] Rudd, J. L., Engle Jr, R. M., Crack growth behavior of center cracked panels under random spectrum loading, *ASTM STP 748*, (1981) 1033-1114. DOI: 10.1520/STP748-EB.
- [106] Youb, Y., Song, J. H., Fatigue crack closure and growth behavior under random loading, *Eng. Fracture Mechanics*, 49(1) (1994) 105-120. DOI:10.1016/0013-7944(94)90115-5.
- [107] Kikukawa, M., Jono, M., Kondo, Y., Mikami, S., Fatigue crack closure and estimation method of crack propagation rate under stationary varying loading conditions including random loading (1st report, Effects of mean load and study on wave counting method), *Trans. Jpn Soc. Mech. Engrs*, 48 (1982)1496-1504.
- [108] Fleck, N. A., Finite-element analysis of plasticity induced crack closure under plane strain conditions. *Eng. Fracture Mechanics*, 25 (1986) 441-449. DOI:10.1016/0013-7944(86)90258-4.
- [109] Wei, L. W., James, M. N., A study of fatigue crack closure in polycarbonate ct specimens. *Eng. Fracture Mechanics*, 66 (2000) 223–42. DOI:10.1016/S0013-7944(00)00014-X.
- [110] Zhao, L. G., Tong, J., Byrne, J., The evolution of the stress–strain fields near a fatigue crack tip and plasticity-induced crack closure revisited. *Fatig. Fract. Eng. Mater. Struct.*, 27(1) (2004) 19–29.
- [111] Chermahini, R. G., Three-dimensional elastic- plastic -finite-element analysis of fatigue crack growth and closure. PhD Thesis, Old Dominion University, Norfolk, VA, (1986).
- [112] Chermahini, R. G., Shivakumar, K. N., Newman, J. C. Jr., Three-dimensional finite-element simulation of fatigue crack growth and closure. *ASTM STP 982*, (1988) 398-413. DOI: 10.1520/STP982-EB.
- [113] Wu J, Ellyin F., A study of fatigue crack closure by elastic–plastic finite element analysis for constant-amplitude loading. *Int. Journal of Fracture*, 82 (1996) 43–65. DOI: 10.1007/bf00017863.